



**INSTALLATION INSTRUCTIONS  
AND  
OPERATION MANUAL**

**FGH EP Series**  
(v2)

**Commercial and Industrial Fire Door Operator**

**Logic Control**

**Restricted Duty Fire Door Operators**

# **IMPORTANT INSTALLATION INSTRUCTIONS**

## **WARNING –To reduce the risk of death or serious injury to persons:**

1. READ AND FOLLOW ALL INSTALLATION INSTRUCTIONS.



### **WARNING**

WARNING! – Components under **extreme spring tension** can cause death or serious injury.

2. Install only on a properly operating and balanced door. A door that is operating improperly could cause death or serious injury. Have trained door systems technicians make all necessary adjustments and repairs to the door before installing the operator.

Note: Fire door spring tension must be adjusted per the manufacturer's installation instructions to allow for automatic closing during fusible link/alarm activation and drop test. If an operator is connected to an alarm release, the door must also close in a power failure unless closing functions are supported by an approved battery back-up system.)

3. Remove any pull ropes that may be installed on the door.
4. Unless the door operator includes an internal lock sensing system, or external electrical interlocks are installed, remove or make all door locks inoperative, or secure locks in the unlocked position to prevent operation with the locks engaged.
5. Install the door operator at least 8 feet or more above the floor if the operator has exposed moving parts. If it is installed less than 8 feet above the floor, any exposed moving parts must be covered or guarded.
6. Install the fusible link cable from the release module on top of the operator per the requirements of NFPA-80.
7. Do not connect the door operator to the source of power until instructed to do so.
8. Locate the control station (open-close-stop push button, key station, or the like):
  - a) within sight of the door, and
  - b) at a minimum height of 5 feet above floors, landings, steps, or any other adjacent walking surface, and
  - c) away from all moving parts of the door
9. Install the Entrapment Warning Placard next to the control station in a prominent location.
10. Make sure the available power supply to be connected to the operator is of the same voltage, frequency, phase and wattage as indicated on the nameplate of the operator.

11. Read and understand the wiring diagram of the operator and the control station and any other equipment to be connected to the operator.
12. Always disconnect power whenever installing or servicing the door operator or door.
13. All wiring must be permanent and comply with National Electrical Code (NEC) and local code requirements.
14. Any change in mounting position may result in a change of operator rotation and consequently in a change of control functions. Consult factory for any changes.
15. If the operator is provided with an auxiliary chain operator, the hand chain must be kept inside the chain bag when operating electrically.
16. For products having a manual release, instruct the end user on the operation of the manual release.

## SPECIFICATIONS

<b>MOTOR</b>	
Type:	Restricted cycle duty (30 cycles per hour)
Horsepower:	1/3 hp, 1/2 hp, 3/4 hp, 1 hp, 1½ hp, 2 hp
Speed:	1700 RPM
Voltage:	115, 230 – 1 phase 208/230, 460, 575 – 3 phase 230 volt 3 phase motor is suitable for use with 208 volts (see <i>Wiring Diagrams and Appendix 5 for wiring change instructions</i> )
Current:	See motor nameplate
<b>ELECTRICAL</b>	
Transformer:	24VAC
Wiring Type:	Momentary pressure open, stop, constant pressure close (provided standard), with provision for momentary pressure close*
Limit Adjustment:	Linear driven, fully adjustable screw type cams.
<b>MECHANICAL</b>	
Drive Reduction:	43:1 (1/3, 1/2 & 3/4 hp), 57:1 (1 & 1½ hp), 82:1 (2 hp)
Output Shaft Speed:	39 RPM (1/3, 1/2 & 3/4 hp), 30 RPM (1 & 1½ hp), 21 RPM (2 hp)
Door Speed:	6 - 8" per sec. average (typical)
Brake:	Solenoid actuated brake
Auxiliary Chain Hoist:	Standard
<b>ENTRAPMENT PROTECTION</b>	
Sensing Edge*:	(Optional) Sensing device attached to the bottom edge of the door.
Non-Contact Device*:	(Optional) Photo eye device.
<p><b>* Per the requirements of UL Standard 325, the door operator is setup for constant pressure to close the door. As an alternative, the door may be provided with at least one <u>monitored</u> sensing device that will reverse the door upon contact with, or upon detecting an obstruction, during closing.</b></p>	

### Notes:

1. A non-contact sensing device (photo eye) can only be used on doors up to 45 ft. wide (or maximum rated range of device if less than 45 ft.). Use a sensing edge to provide entrapment protection on doors over 45 ft. wide.
2. A sensing edge can be used on all doors without size restriction.

## TYPES AND SIZES OF DOORS

Consult factory for details.

## **INSTALLATION INSTRUCTIONS**

### INSTALLATION POSITIONS (for 1/3 hp, 1/2 hp and 3/4 hp)

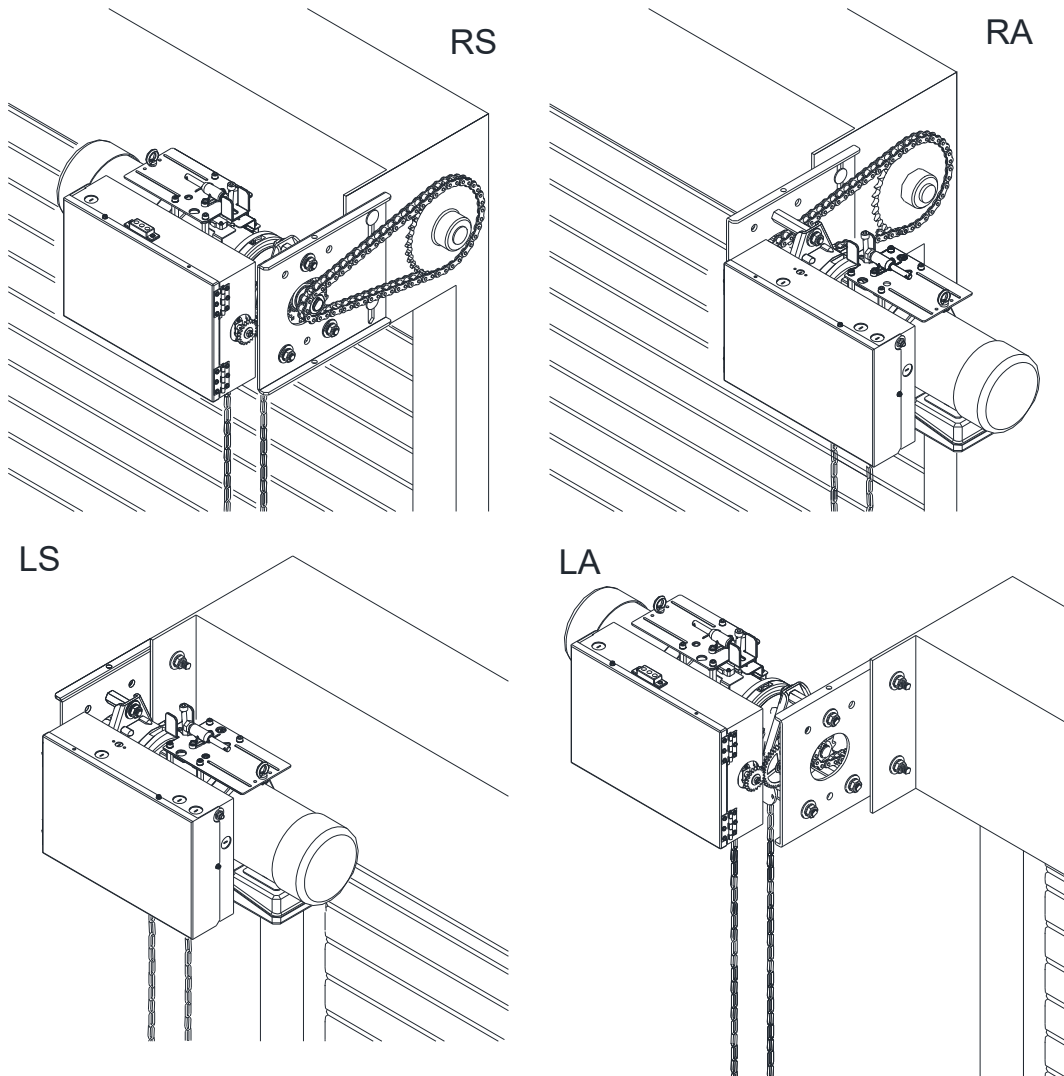

**Consult factory for changes in mounting positions.**

**NOTE:** Any change in mounting position may result in a change of operator rotation and consequently in a change of control functions. Consult factory for any changes. (LS and RA mounting positions are LH operators, RS and LA positions are RH operators)

Operators mounted in alternate positions (LA, RA) require the long mounting legs in lieu of the standard short mounting legs.

## INSTALLATION POSITIONS (for 1 hp, 1-1/2 hp)

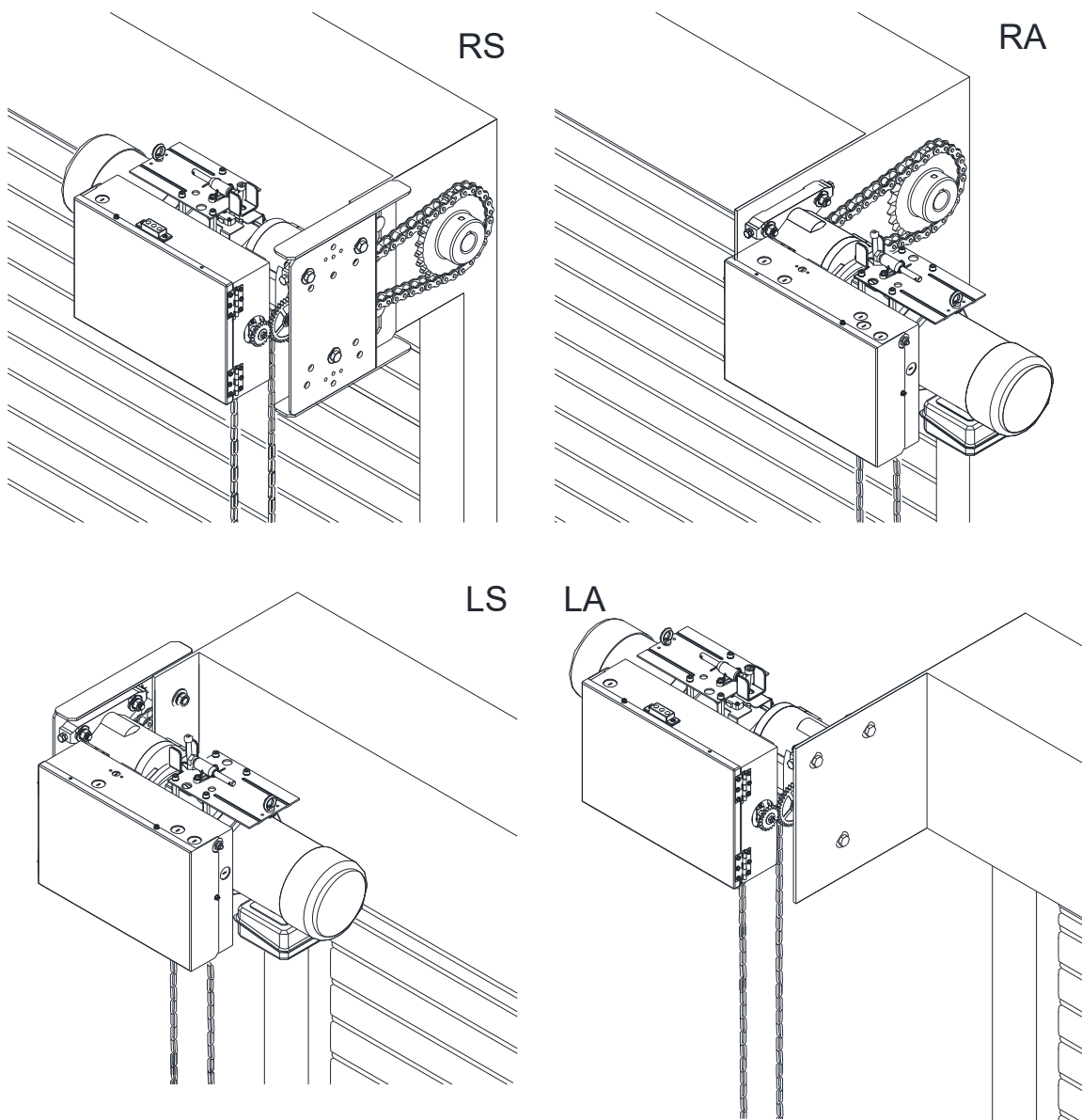

Installation positions for larger horsepower units are similar to as shown above.

Consult factory for changes in mounting positions.

**NOTE:** Any change in mounting position may result in a change of operator rotation and consequently in a change of control functions. Consult factory for any changes. (LS and RA mounting positions are LH operators, RS and LA positions are RH operators)

Operators mounted in alternate positions (LA, RA) require a straight mounting plate in lieu of the standard bent plate.

## **OPERATOR MOUNTING**

1. Before the operator is installed, verify that the door is properly operating and balanced.
2. Make sure the layout of the mounting holes on the bracket is correct.
3. Bolt the operator mounting plate to the door bracket plate.
4. Attach and tighten the three mounting legs to the mounting plate. (Not applicable for larger than 3/4 hp)
5. Mount the operator to the three legs and tighten (for 1/3, 1/2 and 3/4 hp only). For larger horsepower, mount the operator base to the mounting plate.

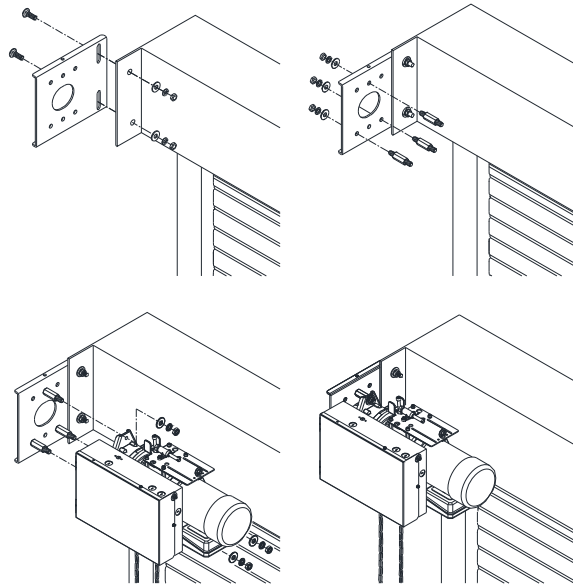

(Figure 1 for 1/3 hp, 1/2 hp and 3/4 hp)

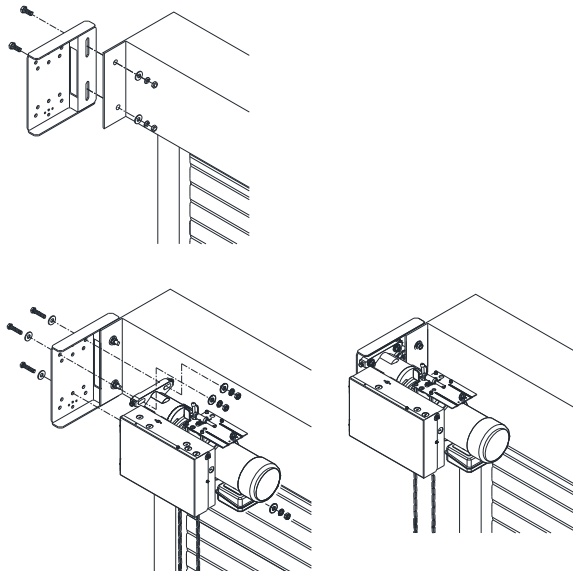

(Figure 2 for 1 hp, 1½ hp)

Mounting for larger horsepower units is similar to as shown above.

6. When the operator assembly is attached to the door bracket, be sure the door driven sprocket is properly aligned with the operator drive sprocket before securing the driven sprocket to the shaft. (See Figure 1 for 1/3 hp, 1/2 hp and 3/4 hp; see Figure 2 for the 1 hp and 1½ hp)
7. The bracket must provide adequate support for the operator. Prevent play between the operator and the door shaft. The operator must be securely attached with the drive shaft parallel to the door shaft. It may be necessary to field brace the operator/bracket.

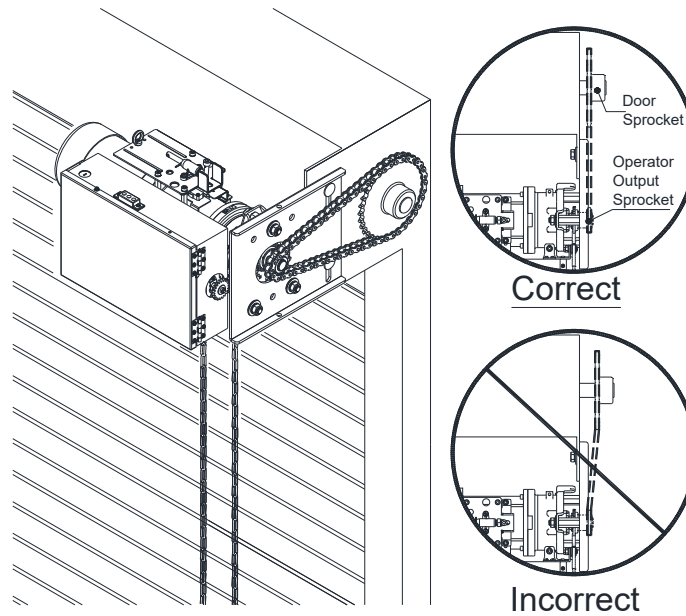

(Figure 1 for 1/3 hp, 1/2 hp and 3/4 hp)

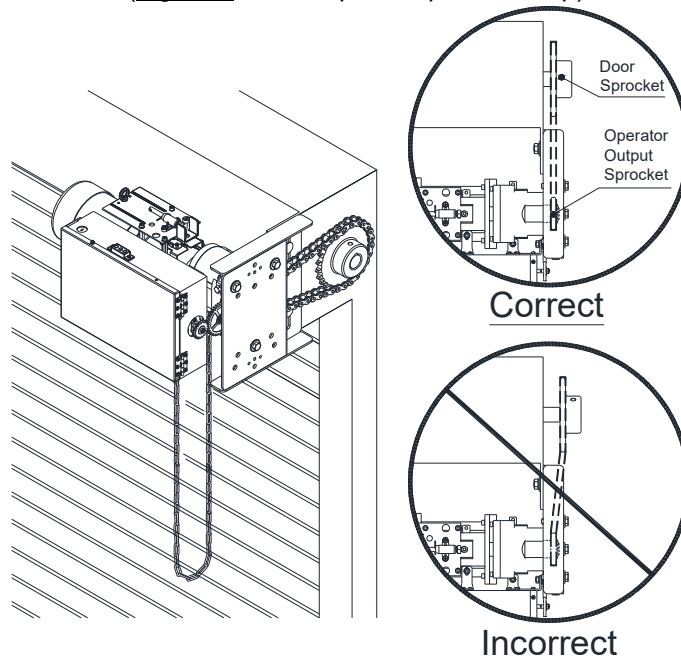

(Figure 2 for 1 hp, 1½ hp)



## DRIVE CHAIN ADJUSTMENT

**NOTE: Use correct type, size and proper length of roller chain.**

1. Adjust the drive chain by tilting or move the operator so that there is about 1/4" of slack when the chain is depressed.

Note: The set screws on the operator base (S1) may be used to make the adjustment. (See Figure 1- S1 location for 1/3 hp, 1/2 hp, 3/4 hp), (See Figure 2 - T1, T2 for 1 hp, 1½ hp).

2. Once the drive chain has been tightened and the base leg screws have been set, then tighten the operator screws.

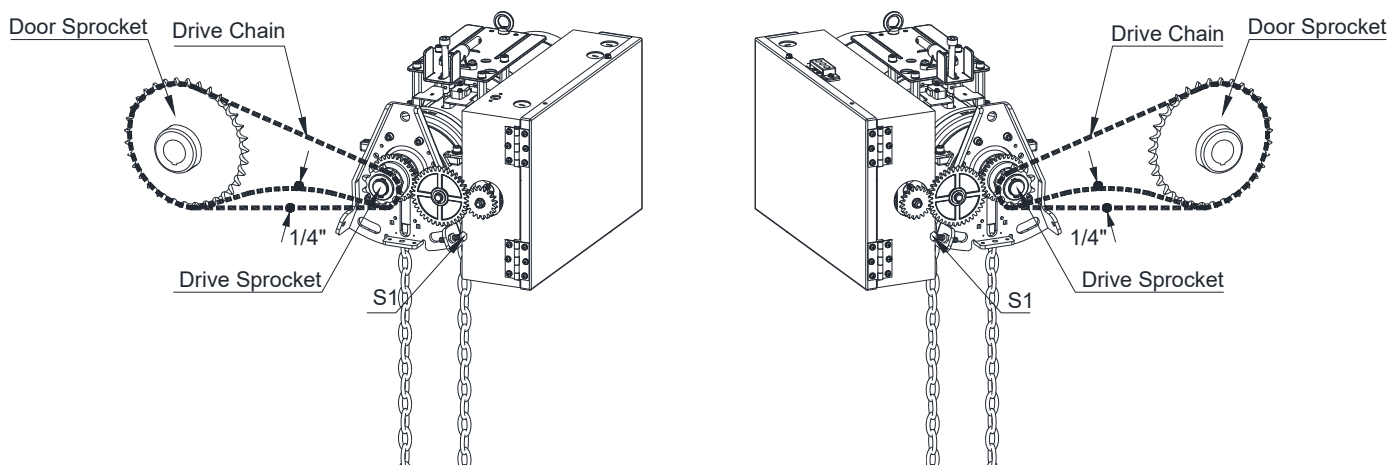

(Figure 1 for 1/3 hp, 1/2 hp and 3/4 hp)

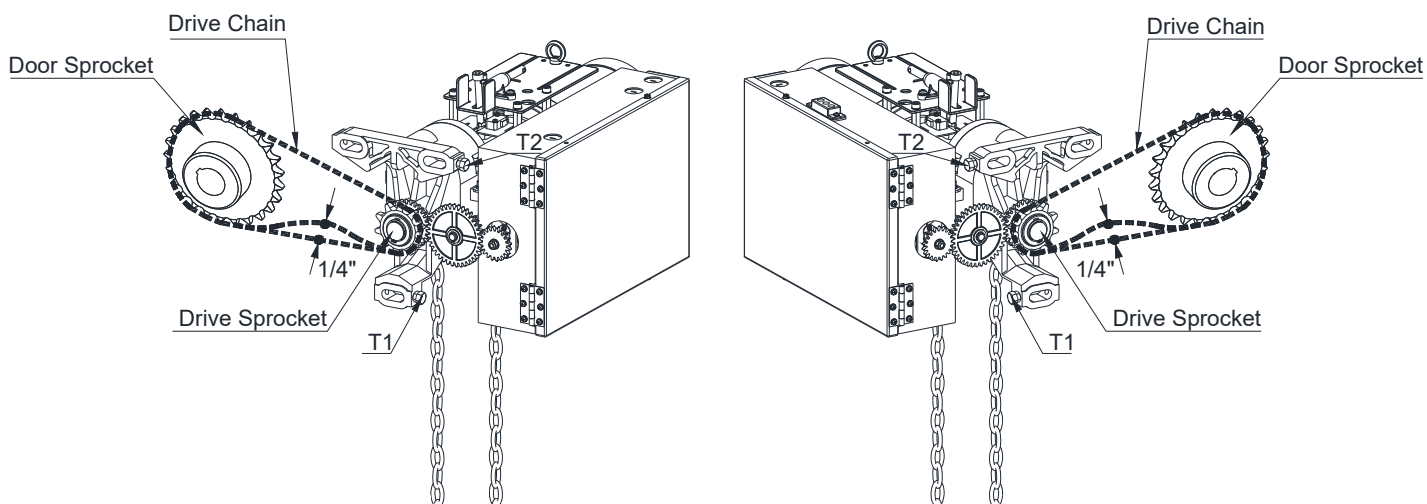

(Figure 2 for 1 hp and 1½ hp)

## HAND CHAIN ADJUSTMENT

If the hand chain is too long, cut and reconnect the chain with the different color connecting link provided. Completely close the connecting link so it is properly aligned.

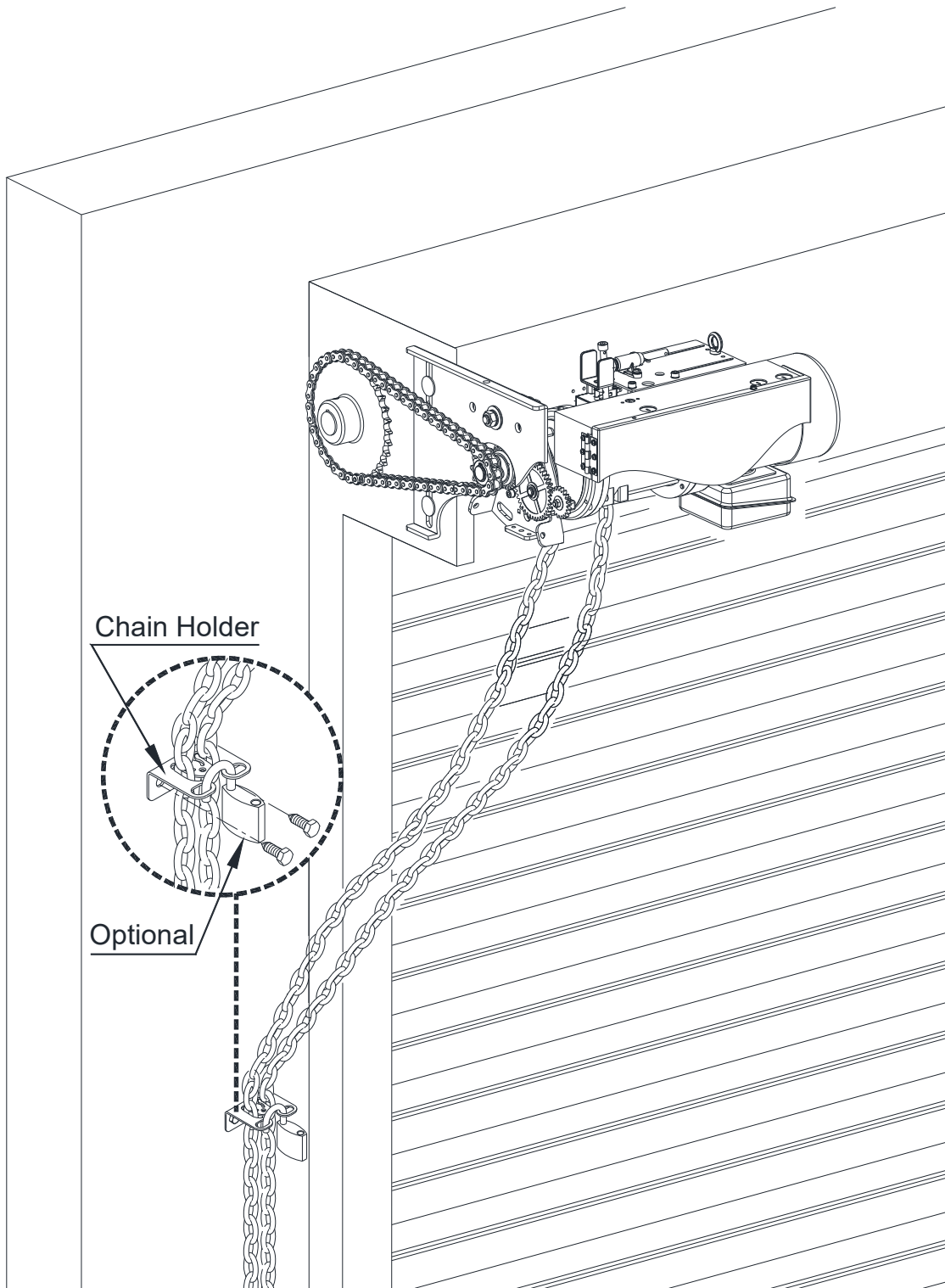

## **BRAKE RELEASE LEVER**

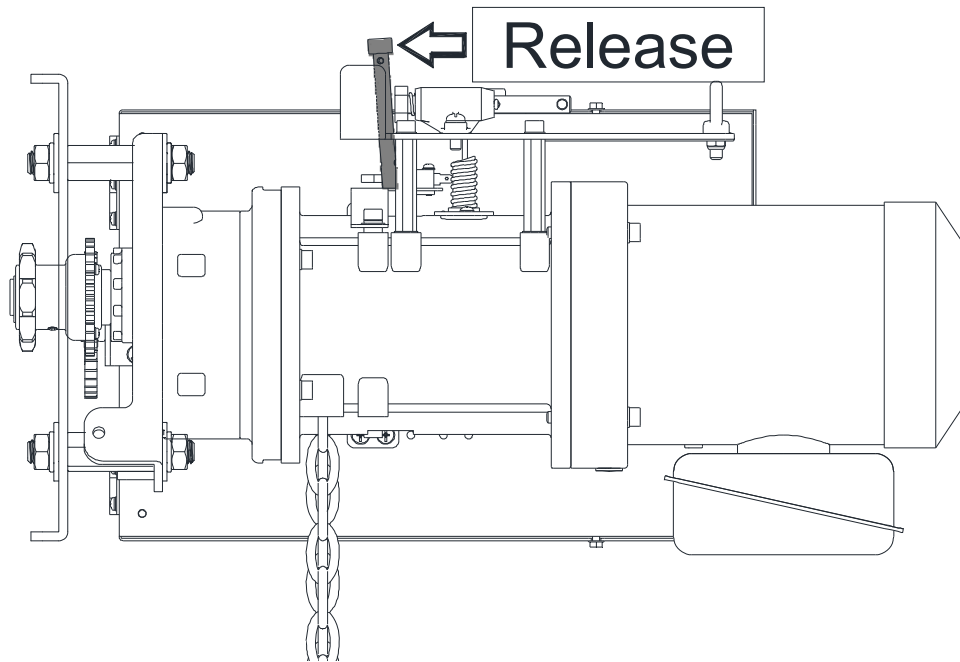

### **WARNING**

Releasing the door operator brake, or loosening or removing any part of the door operator drive system, can cause the door to close and cause death or serious injury. **Do NOT release the brake, or loosen or remove any part of the door operator drive system**, unless the door is closed, or the curtain is secured in the open position to prevent uncoiling.

1. Pressing the brake release lever will release the motor brake and can cause the door to move uncontrolled.
2. Limit switch LSA1 is activated when the brake release lever is pressed – see wiring diagrams for details.
3. Open-close-stop controls do not function while the brake release lever is pressed.
4. Fire doors using this operator have counterbalance springs that are adjusted during installation to allow the door to close automatically upon activation of the door operator release mechanism (brake release) without requiring a loss of spring tension.

## LIMIT SWITCH ADJUSTMENT

**Make sure the limit cams are positioned between the limit switch actuators before proceeding with adjustments.**

1. Open the control panel cover.
2. Open or close the door part way to determine the direction of travel of the limit switch cams.
3. Open or close the door to the desired position.



**WARNING** Disconnect power before adjusting limit switch cams.

4. While pressing the spring-loaded plate (G), which holds the limit switch cams in place, adjust the limit switch cam (E or F) until the micro switch (C or D) clicking sound is heard.
5. If the limit switch cam cannot be rotated to its desired position, release the plate and move the door away from the desired position, then adjust the limit switch cam to its desired position. It may be necessary to repeat this step until the exact position has been reached.
6. Repeat step 3 and 4 for the opposite direction. Adjust close limit cams so that actuator is engaged as door fully closes to the floor.
7. "B" is usually the sensing edge cut-off switch and can be adjusted to accommodate sensing edge cut-off position. It is recommended that the switch position be adjusted as low as possible without interfering with close limit switch function.

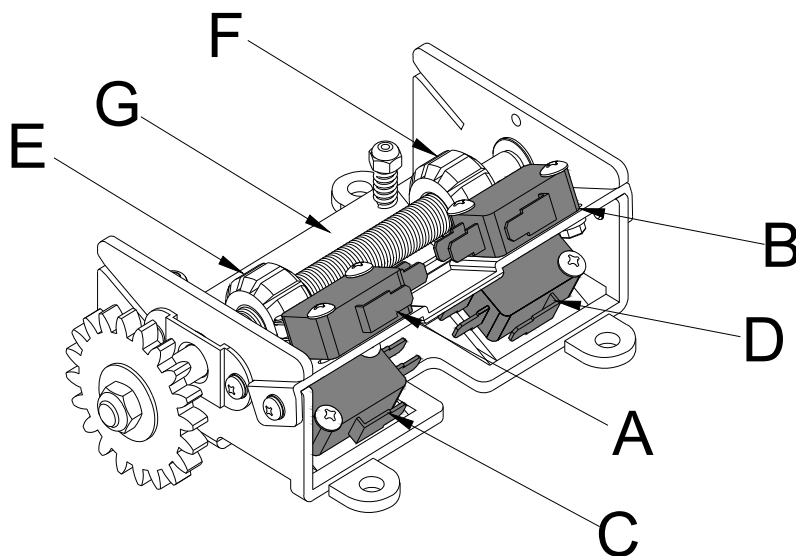

**NOTE: "C" is usually the open limit switch and "D" is usually the close limit switch.**

## WIRING INSTRUCTIONS



**Disconnect power at the fuse box before proceeding with any wiring.**

### **WARNING**

1. Do not install any wiring or attempt to run this operator without checking the wiring diagram located on the inside of the control box cover.
2. Do not turn on power until you have finished making all power and control wiring connections.
3. Do not run power and control wiring in the same conduit.
4. Any wire connected to the control panel must be protected by conduit or other means to ensure the safety and permanency of the wiring.
5. Use copper wire inside the control panel.
6. A separate fuse line of adequate capacity is needed for the operator.
7. The operator must be properly grounded. The ground screw, painted green, is located inside the control panel.
8. For an operator, system, or external device requiring field installed wiring between a Class 2 output of an operator and an external device, the type of wiring shall be R/C (AVLV2/8), AWM, min. 22 AWG, rated 60°C, with VW-1/FT2.



### **WARNING**

**Failure to properly ground the operator could result in electric shock and death or serious injury.**



### **WARNING**

**Unless the operator includes an internal lock sensing system, or external electrical interlocks are installed, remove or make all door locks inoperative, or secure locks in the unlocked position. Failure to disable the locks could result in damage to the door or operator.**

## CONTROL WIRING



### WARNING

If the door is not visible from the control station, or if any device other than a control station requiring constant pressure to close the door is used, a monitored sensing device must be installed on the door. Failure to do so could result in serious injury or death to person(s) trapped beneath the door.

1. Complete limit switch adjustments before making any sensing edge/non-contact device wiring connections to the operator.

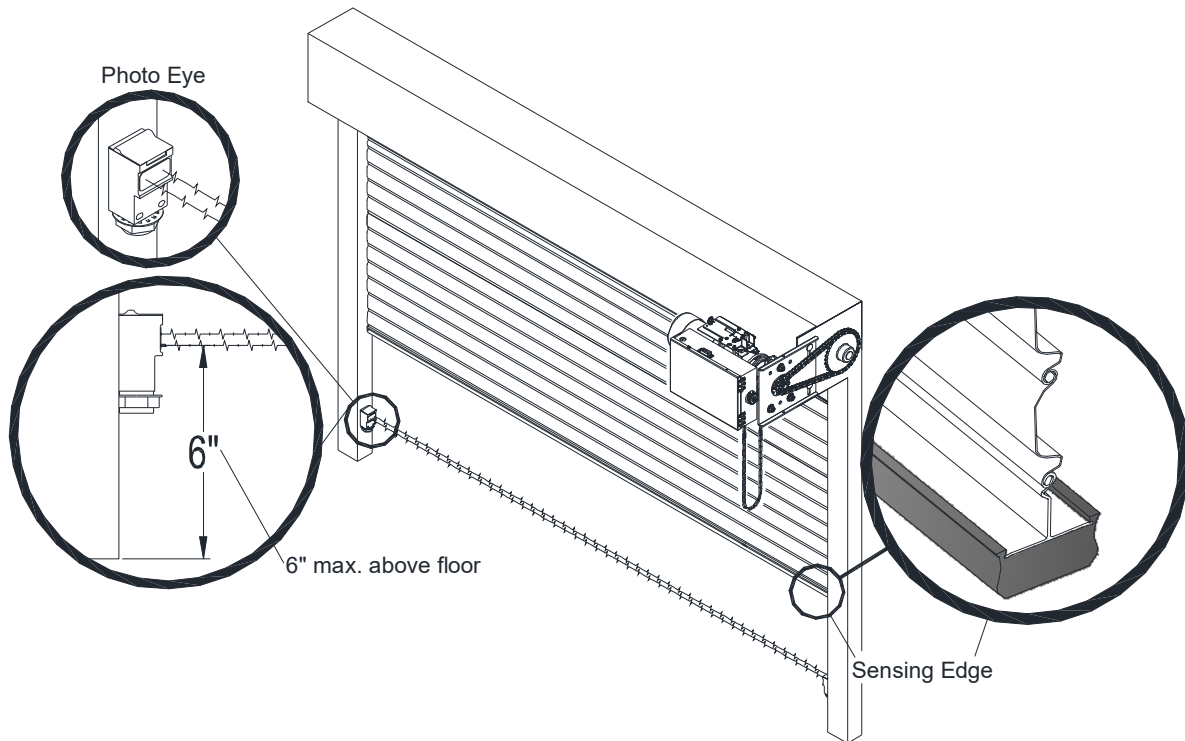

### Entrapment Device Options:

Sensing Module	Device Manufacturer	Model
<b>ELR</b> 2-wire resistive sensing edge	Miller Edge Inc. * End of Line resistor type edge must have model number with Suffix T2.	ME110*, ME111*, ME120*, ME123*, ME112*, ME113*, ME116*, ME117*
		MT21*, MU21*, MT22*, MU22*, MC22*, MU33*, MC271*, CPT223*
		MEL-TXYY, MEL-RXYY
		RB-G-K10
	ASO	GE225, GE125, GE245, GE F45, GE F50, GE F56, GE F65, GE F85, GE F115
<b>IR</b> Monitored photo eye	FRABA Inc.	Optical Edge Sensors and Photo Eyes, Models OPTOEDGE, OPTOEYE, OSE, OPE, OSE-P, OSE-R, OSE-T, RAY-N Reflective Photo Eye, Models Ray/RT -1004, -2004
	Martec Access Products Inc.	1266
	Miller Edge Inc.	IG2, MIRM RB-D-K10

**Note:** Refer to sensing device manufacturer for specific installation and maintenance requirements.

- If more than one monitored sensing device is to be used, each device must be connected to a separate ELR/IR sensing module to provide separate monitoring functions. Consult factory for a multiple device adapter.



## WARNING

**Do not install a timer to close the door unless some type of monitored entrapment protection device has been installed. Failure to do so may result in death or serious injury to person(s) trapped beneath the door.**

- If a timer to close (reclose timer) is to be used, a compatible reclose timer module is required that will not interfere with the monitoring of sensing device functions. Consult factory for the correct reclose timer module,



## WARNING

**Disconnect power at the fuse box before proceeding with any wiring.**

- Locate the control station at a minimum height of 5 feet above the floor, and where the user can clearly see the operation of the door. Mount the enclosed placard adjacent to or near the door.



## WARNING

**Controls shall be located far enough away from the door, or positioned such that the user is prevented from coming in contact with the door, while operating the controls.**

- Do not run control wiring in the same conduit as power wiring.
- Any wires connected to the control panel must be protected by conduit or other means to ensure the safety and permanency of the wiring.



## WARNING

**Do not install radio controls (receiver/transmitter) to operate the door unless some type of monitored entrapment protection device has been installed. Failure to do so may result in death or serious injury to person(s) trapped beneath the door.**



## WARNING

**Changing from left hand to right hand or vice versa could result in change of control wiring. Consult factory for details.**

- After installation, be sure that the operator, controls, and sensing edge or other entrapment protection devices have been tested and function properly.

# A. Control Function:

A.

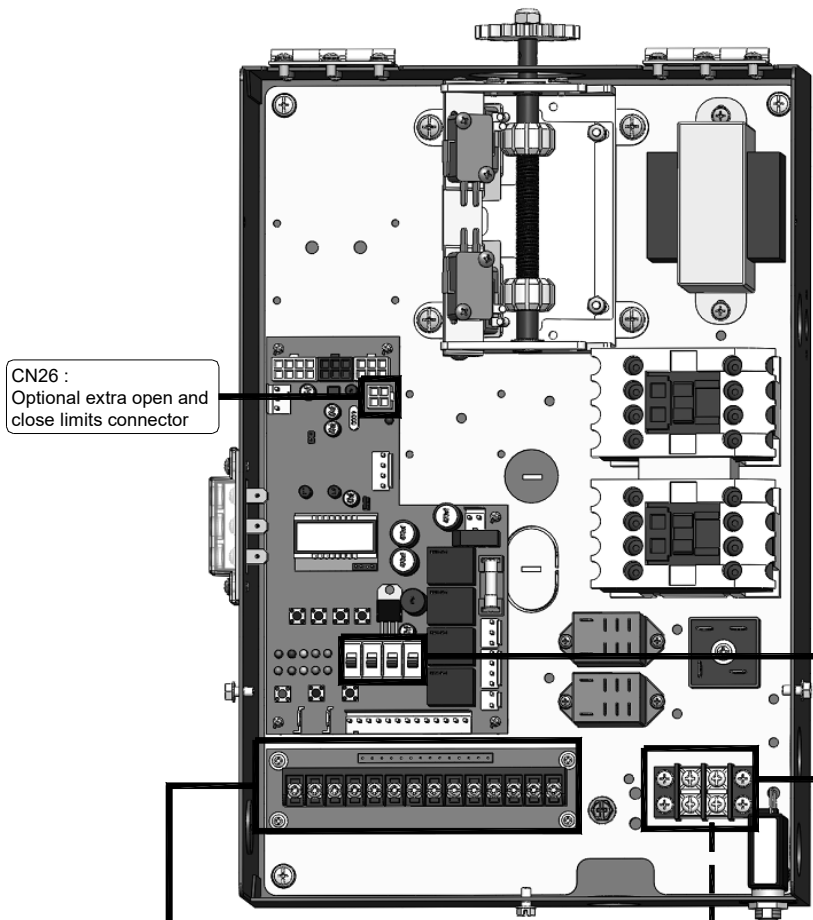

A-2.

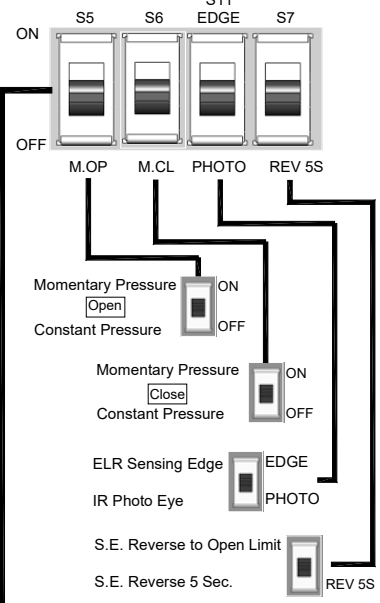

Single-phase power source  
See operator plate for correct voltage.

A-3.

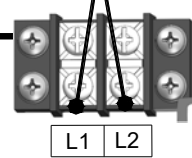

A-1.

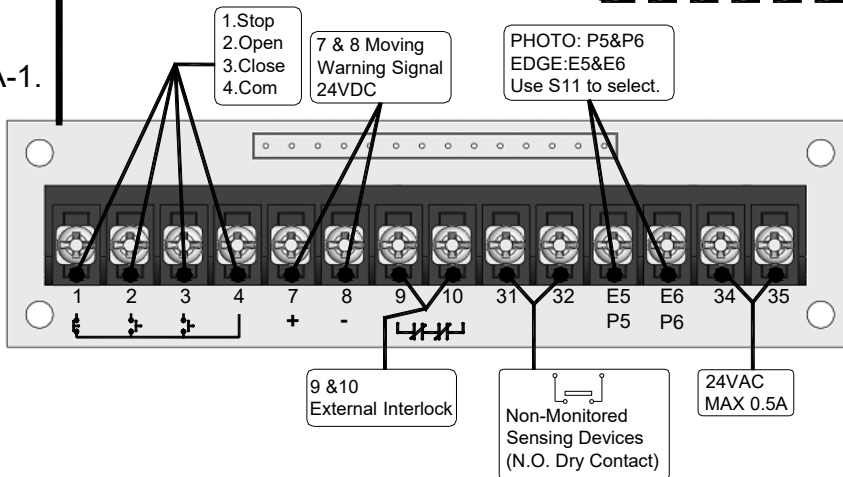

A-3.

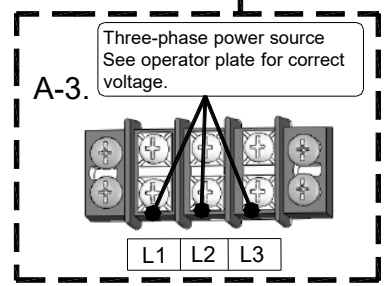

- ❖ A one-second delay on reverse is standard.
- ❖ When the door is closing, pushing the “Open” or “Stop” button will stop the door from moving.
- ❖ When the door is closing, the radio control transmitter can stop and reverse the door at anytime.



## B. Auxiliary Function:

B.

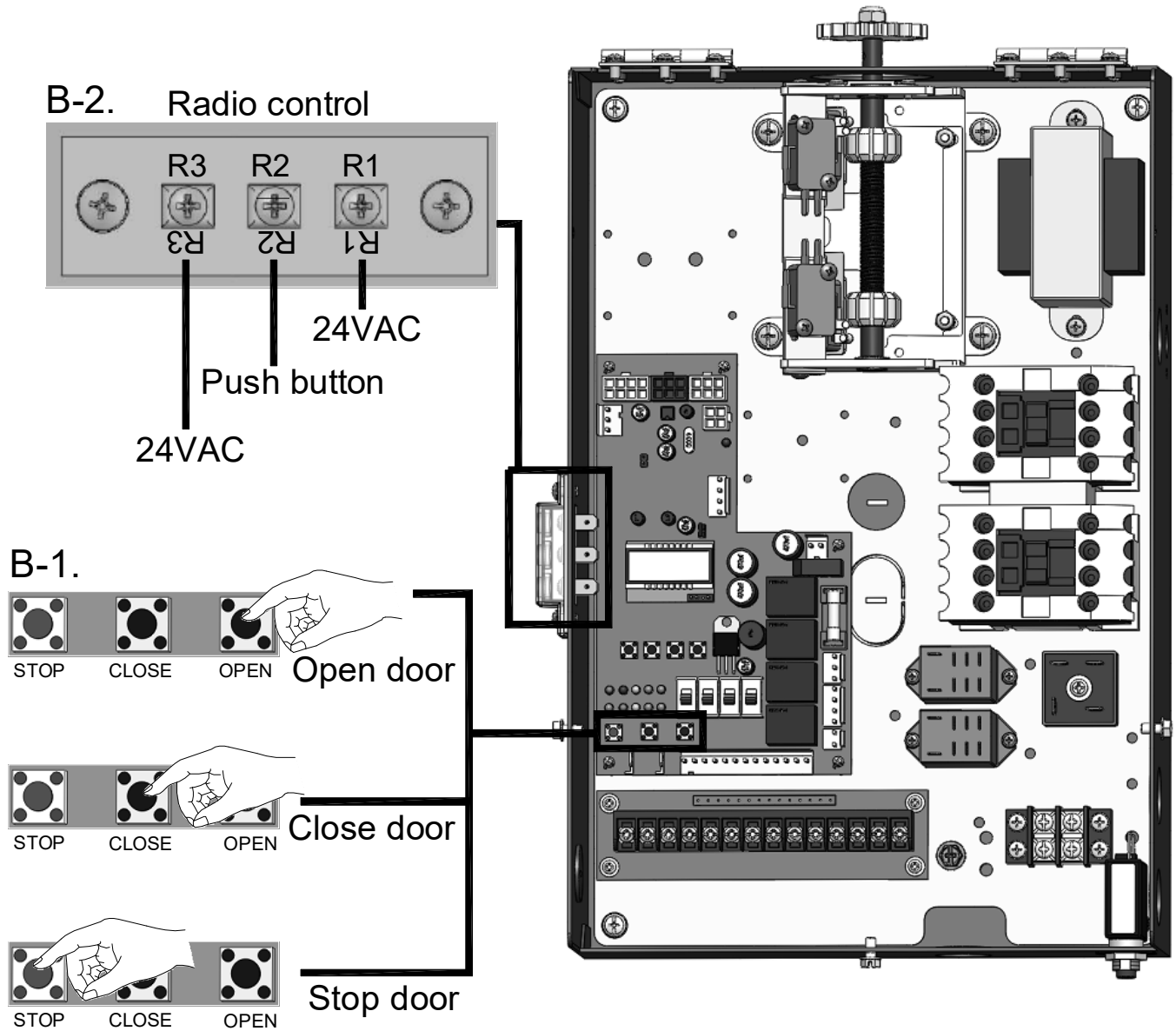

❖ Refer to appendix illustration for connection of single and multiple control stations.

## C. Timer Instruction:

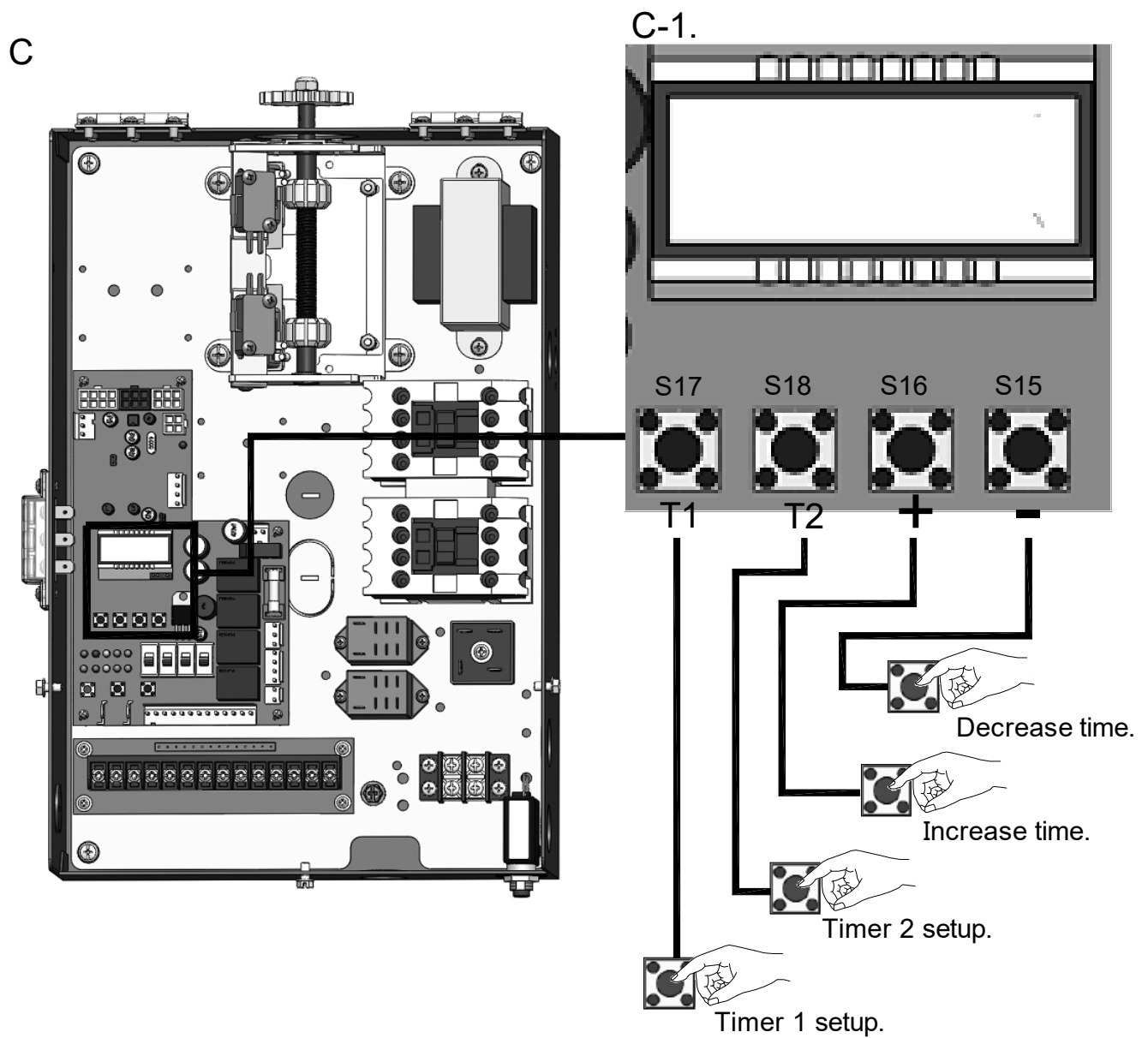





(1) Timer 1 – Mid-open timer: Timer starts counting when door leaves close limit. Door stops after opening for set time. Pressing open again at mid-open position will cause door to open limit.

Timer 2 – Close timer: Timer is active when door stops and is not at close limit.



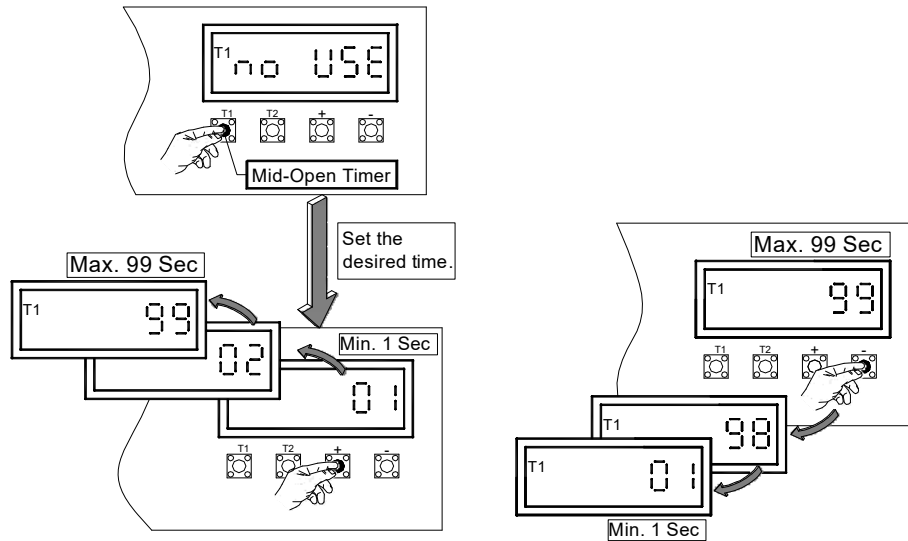

(2) Standard Mode: Cycle counter

### (3) To Set Timer 1 (Mid-open Timer):

- Press  and hold for 5 seconds. Display will flash.
- Use  or  to increase or to decrease time.
- Press  to save setting. Without pressing, no adjustment is saved.



### (4) To Set Timer 2 (Reclose Timer):

- Press  and hold for 5 seconds. Display will flash.
- Use  or  to increase or to decrease time.
- Press  to save setting. Without pressing, no adjustment is saved.

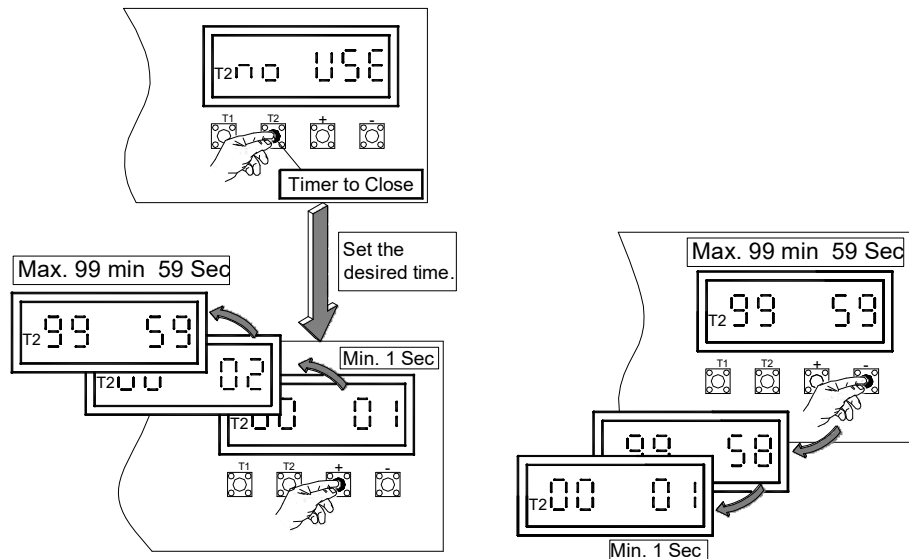

## D. LCD Display Instruction:

Display	Status	Display	Status
	T1 setting		Door closing
	T2 setting		Door opening
	T1 or T2 setting completed		

## E. Light Indication:

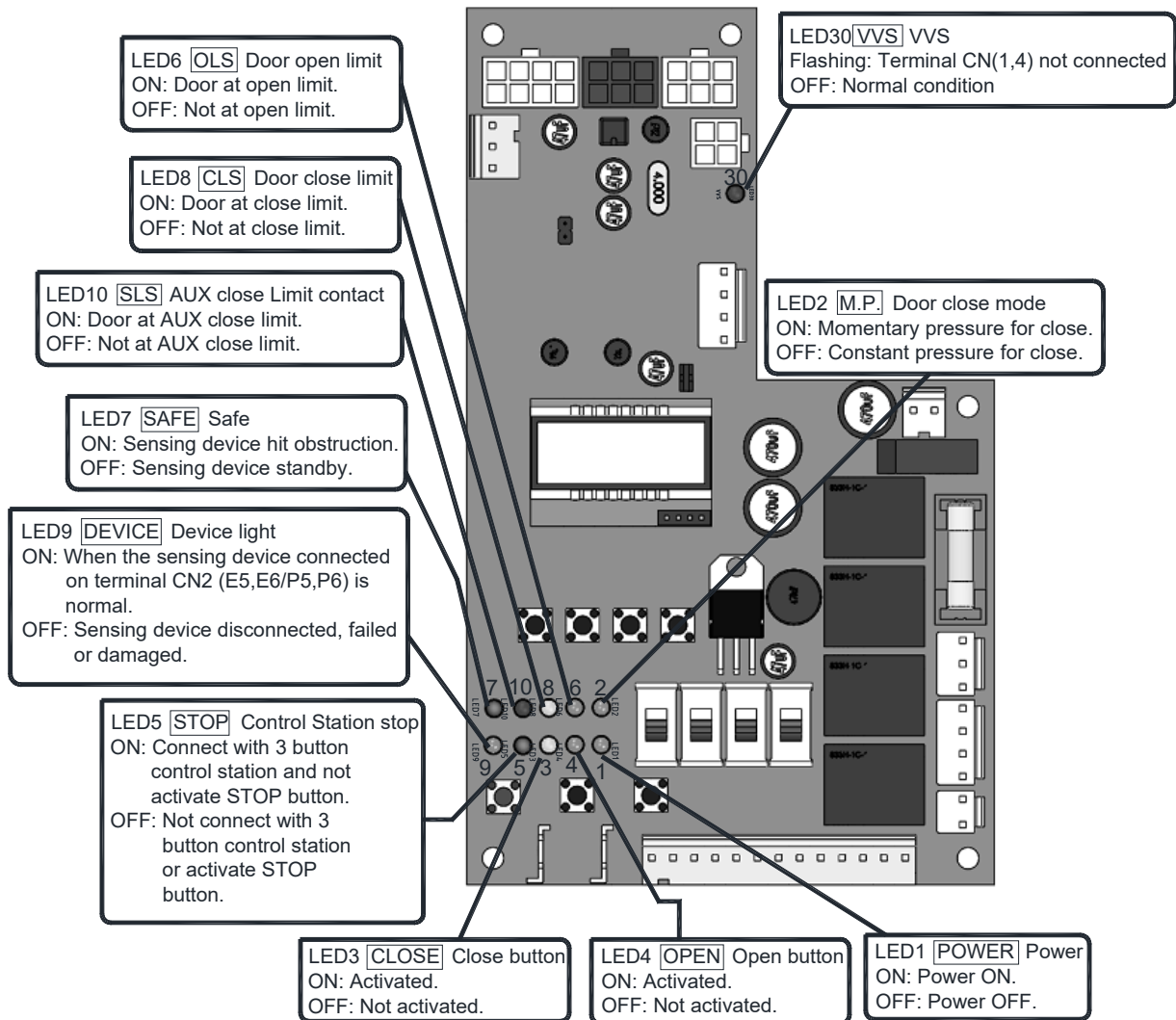

FGH 115V 1 PHASE 50/60HZ LH (FGEP BOARD)  
(FOR FGH 3311EP)

EE 608-3311EP L  
V3.08

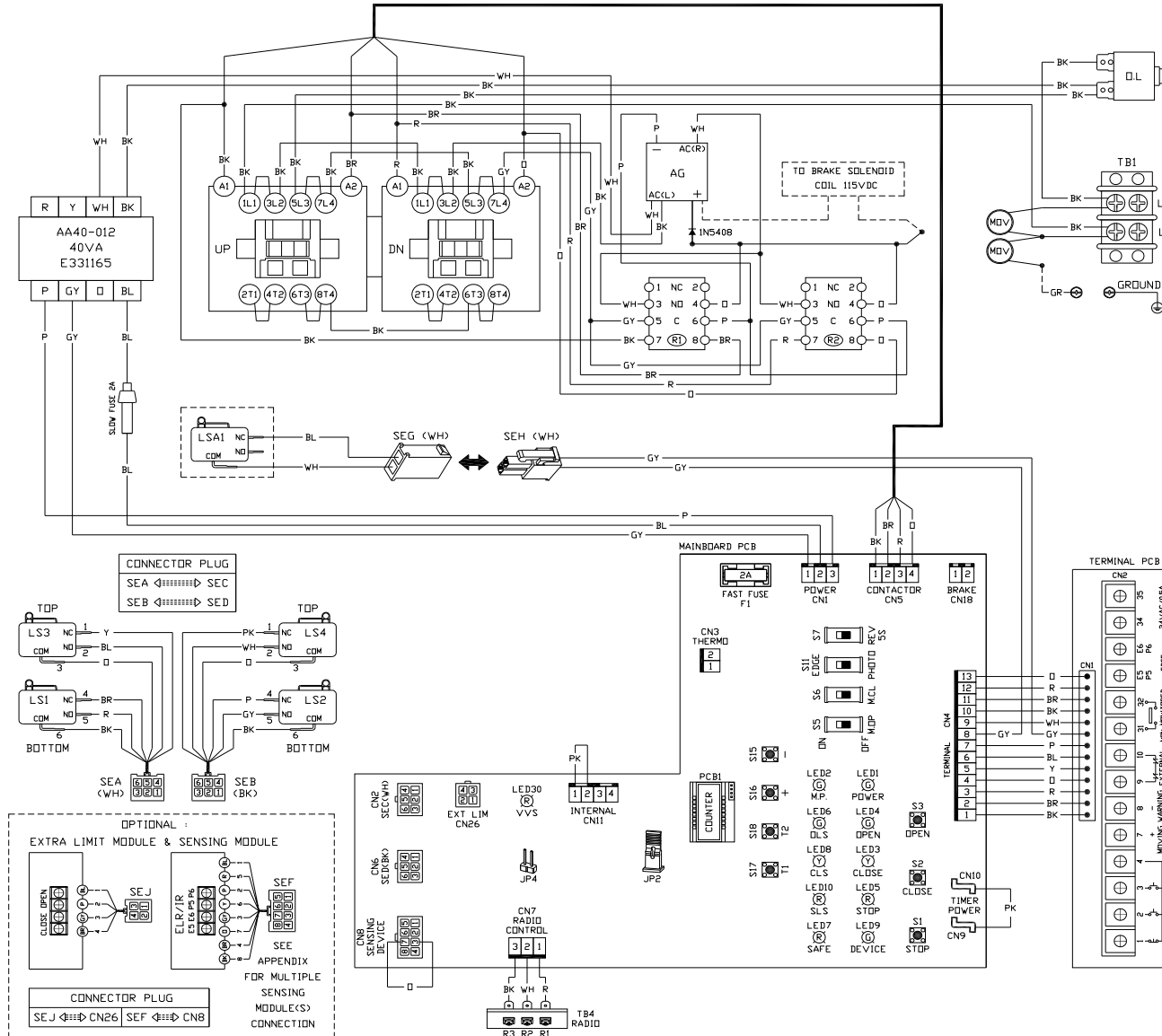

- NOTES :
1. R1-OPEN RELAY (COIL 24VAC)
  2. R2-CLOSE RELAY (COIL 24VAC)
  3. MOV-TNR 14V 47K
  4. SEA-LS1 & LS3 MICROSWITCH CONNECTOR
  5. SEB-LS2 & LS4 MICROSWITCH CONNECTOR
  6. LSA1-PLUNGER SWITCH DF FUSIBLE LINK

- MAINBOARD PCB :
1. SEC-OPEN CONTROL CONNECTOR
  2. SEC-CLOSE CONTROL CONNECTOR
  3. CN8-SENSING MODULE CONNECTOR
  4. CN9 & CN10-JUMP FOR ENABLING RECLOSE TIMER
  5. CN26-OPTIONAL EXTRA OPEN AND CLOSE LIMITS CONNECTOR
  6. S5-MOMENTARY/CONSTANT PRESSURE OPEN
  7. S6-MOMENTARY/CONSTANT PRESSURE CLOSE
  8. S7-REVERSE TO OPEN LIMIT OR REVERSE 5 SEC.
  9. S11-EDGE/PHOTO EYE SENSING DEVICE SELECTION  
REMOVE JUMPER FOR CLOSE WARNING SIGNAL ONLY.
  10. JP2-OPEN AND CLOSE WARNING SIGNAL (JUMPED)  
REMOVE JUMPER FOR CLOSE WARNING SIGNAL ONLY.
  11. JP4-RESERVED, INTERNAL USE.

- TERMINAL PCB - CN2 :
1. CTRLNL STATION-STOP
  2. CTRLNL STATION-OPEN
  3. CTRLNL STATION-CLOSE
  4. CTRLNL STATION-COMMON
- 78&8 DDR MOVING WARNING SIGNAL 24VDC  
98&10 EXTERNAL INTERLOCK  
31&32 NON-MONITORED SENSING DEVICES (N.O. DRY CONTACT)  
E5&E6/PS&P6 SENSING DEVICE CONNECTION  
34&35 24VAC POWER, MAX 0.5A

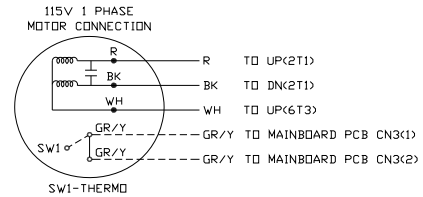

2017.06.09

FGH 115V 1 PHASE 50/60HZ RH (FGEP BOARD)  
(FOR FGH 3311EP)

EE 608-3311EP R  
V3.08

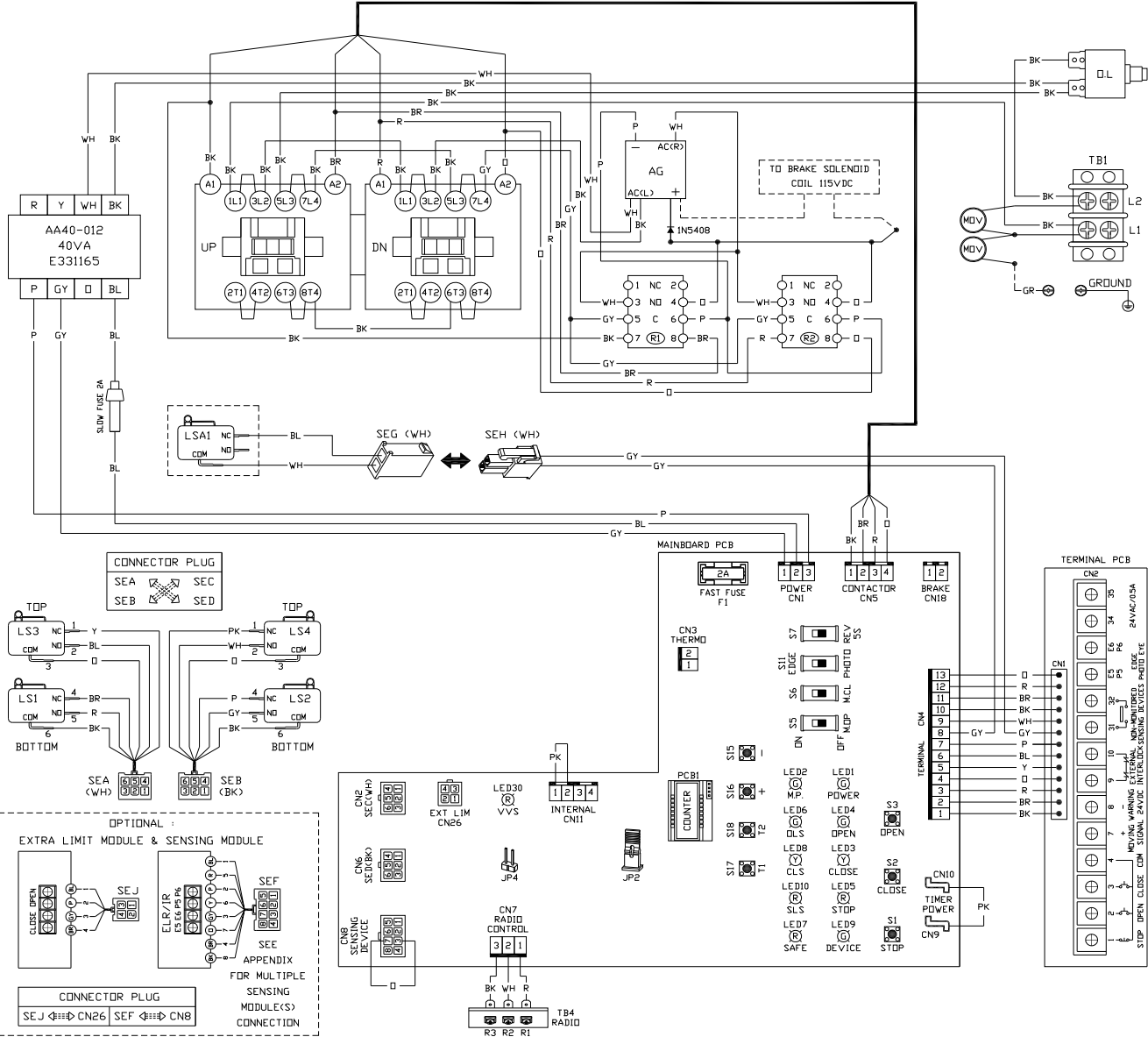

- NOTES :
1. R1-OPEN RELAY (COIL 24VAC)
  2. R2-CLOSE RELAY (COIL 24VAC)
  3. MOV-TNR 14V 471K
  4. SEA-LS1 & LS3 MICROSWITCH CONNECTOR
  5. SEB-LS2 & LS4 MICROSWITCH CONNECTOR
  6. LSA1-PLUNGER SWITCH OF FUSIBLE LINK

- MAINBOARD PCB :
1. SEC-OPEN CONTROL CONNECTOR
  2. SEC-CLOSE CONTROL CONNECTOR
  3. CN8-SENSING MODULE CONNECTOR
  4. CN9 & CN10-JUMP FOR ENABLING RECLOSE TIMER
  5. CN26-OPTIONAL EXTRA OPEN AND CLOSE LIMITS CONNECTOR
  6. S5-MOMENTARY/CONSTANT PRESSURE OPEN
  7. S6-MOMENTARY/CONSTANT PRESSURE CLOSE
  8. S7-REVERSE TO OPEN LIMIT OR CLOSE LIMITS 5 SEC.
  9. S11-EDGE/PHOTO EYE SENSING DEVICE SELECTION
  10. JP2-OPEN AND CLOSE WARNING SIGNAL (JUMPED)  
REMOVE JUMPER FOR CLOSE WARNING SIGNAL ONLY.
  11. JP4-RESERVED, INTERNAL USE.

- TERMINAL PCB - CN2 :
- 1 CONTROL STATION-STOP
  - 2 CONTROL STATION-OPEN
  - 3 CONTROL STATION-CLOSE
  - 4 CONTROL STATION-COMMON
  - 7&8 DOOR MOVING WARNING SIGNAL 24VDC
  - 9&10 EXTERNAL INTERLOCK
  - 31&32 NON-MONITORED SENSING DEVICES (N.D. DRY CONTACT)
  - E5&E6/P5&P6 SENSING DEVICE CONNECTION
  - 34&35 24VAC POWER, MAX 0.5A

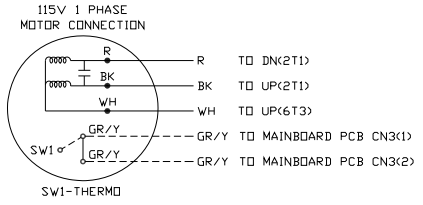

2017.06.09

FGH 115V 1 PHASE 50/60HZ LH (FGEP BOARD)  
 (FOR FGH 5011EP, 7511EP, 10011EP, 15011EP, 20011EP)

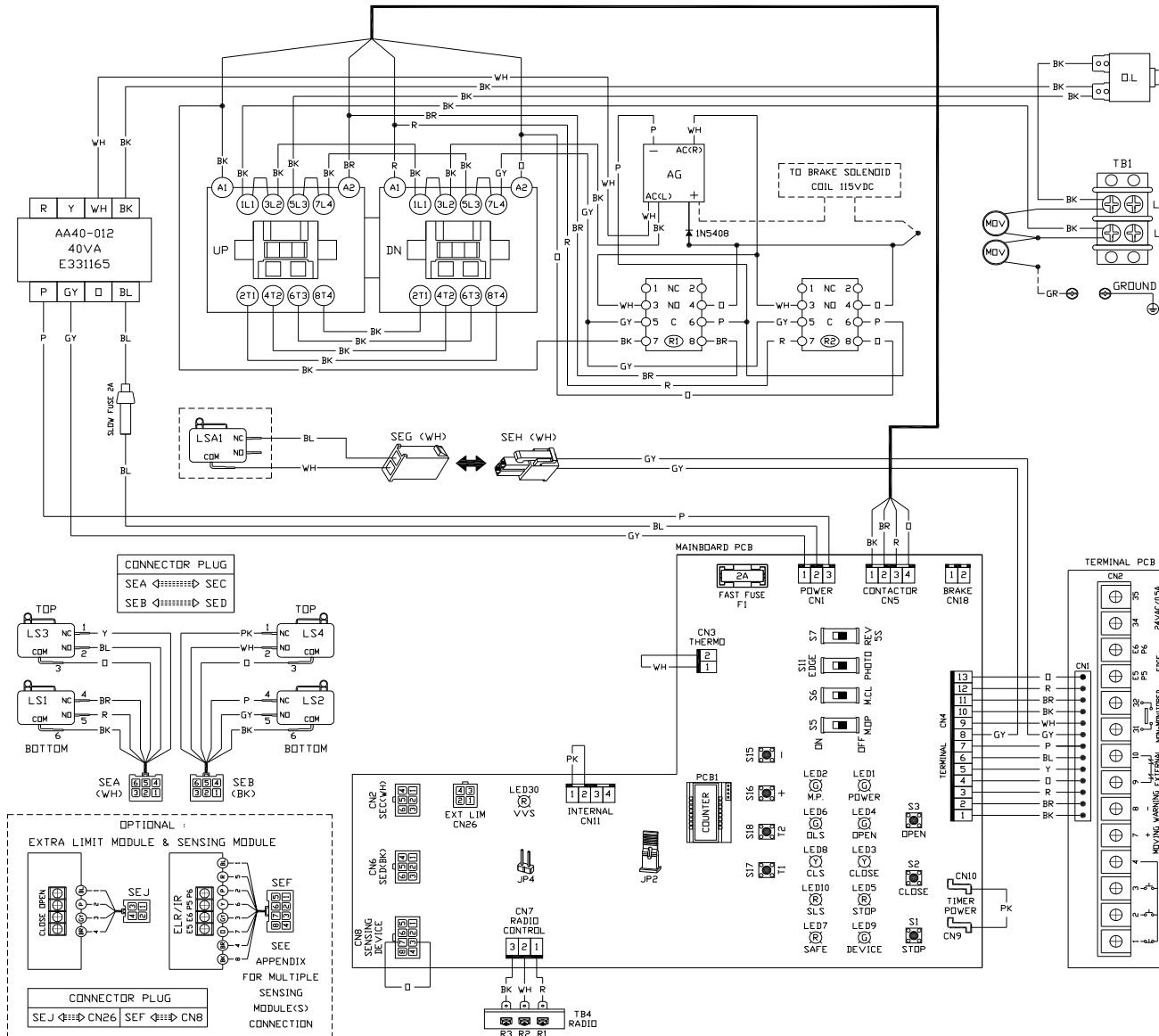

EE 608EP L  
 V3.08

- NOTES :
1. R1-OPEN RELAY (COIL 24VAC)
  2. R2-CLOSE RELAY (COIL 24VAC)
  3. MOV-TNR 14V 471K
  4. SEA-LS1 & LS3 MICROSWITCH CONNECTOR
  5. SEB-LS2 & LS4 MICROSWITCH CONNECTOR
  6. LSA1-PLUNGER SWITCH OF FUSIBLE LINK

- MAINBOARD PCB :
1. SEC-OPEN CONTROL CONNECTOR
  2. SEC-CLOSE CONTROL CONNECTOR
  3. CN8-SENSING MODULE CONNECTOR
  4. CN9 & CN10-JUMP FOR ENABLING RECLOSE TIMER
  5. CN26-OPTIONAL EXTRA OPEN AND CLOSE LIMITS CONNECTOR
  6. S5-MOMENTARY/CONSTANT PRESSURE OPEN
  7. S6-MOMENTARY/CONSTANT PRESSURE CLOSE
  8. S7-REVERSE TO OPEN LIMIT OR REVERSE 5 SEC.
  9. S11-EDGE/PHOTO EYE SENSING DEVICE SELECTION
  10. JP2-OPEN AND CLOSE WARNING SIGNAL (JUMPED)  
 REMOVE JUMPER FOR CLOSE WARNING SIGNAL ONLY.
  11. JP4-RESERVED, INTERNAL USE.

- TERMINAL PCB - CN2 :
- 1 CONTROL STATION-STOP
  - 2 CONTROL STATION-OPEN
  - 3 CONTROL STATION-CLOSE
  - 4 CONTROL STATION-COMMON
- 7&8 DDR MOVING WARNING SIGNAL 24VDC  
 9&10 EXTERNAL INTERLOCK  
 31&32 NON-MONITORED SENSING DEVICES (N.O. DRY CONTACT)  
 E5&E6/P5&P6 SENSING DEVICE CONNECTION  
 34&35 24VAC PDWER, MAX 0.5A

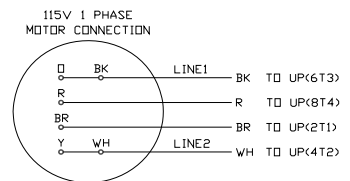

2017.06.09

FGH 115V 1 PHASE 50/60HZ RH (FGEP BOARD)  
 (FOR FGH 5011EP, 7511EP, 10011EP, 15011EP, 20011EP)

EE 608EP R  
 V3.08

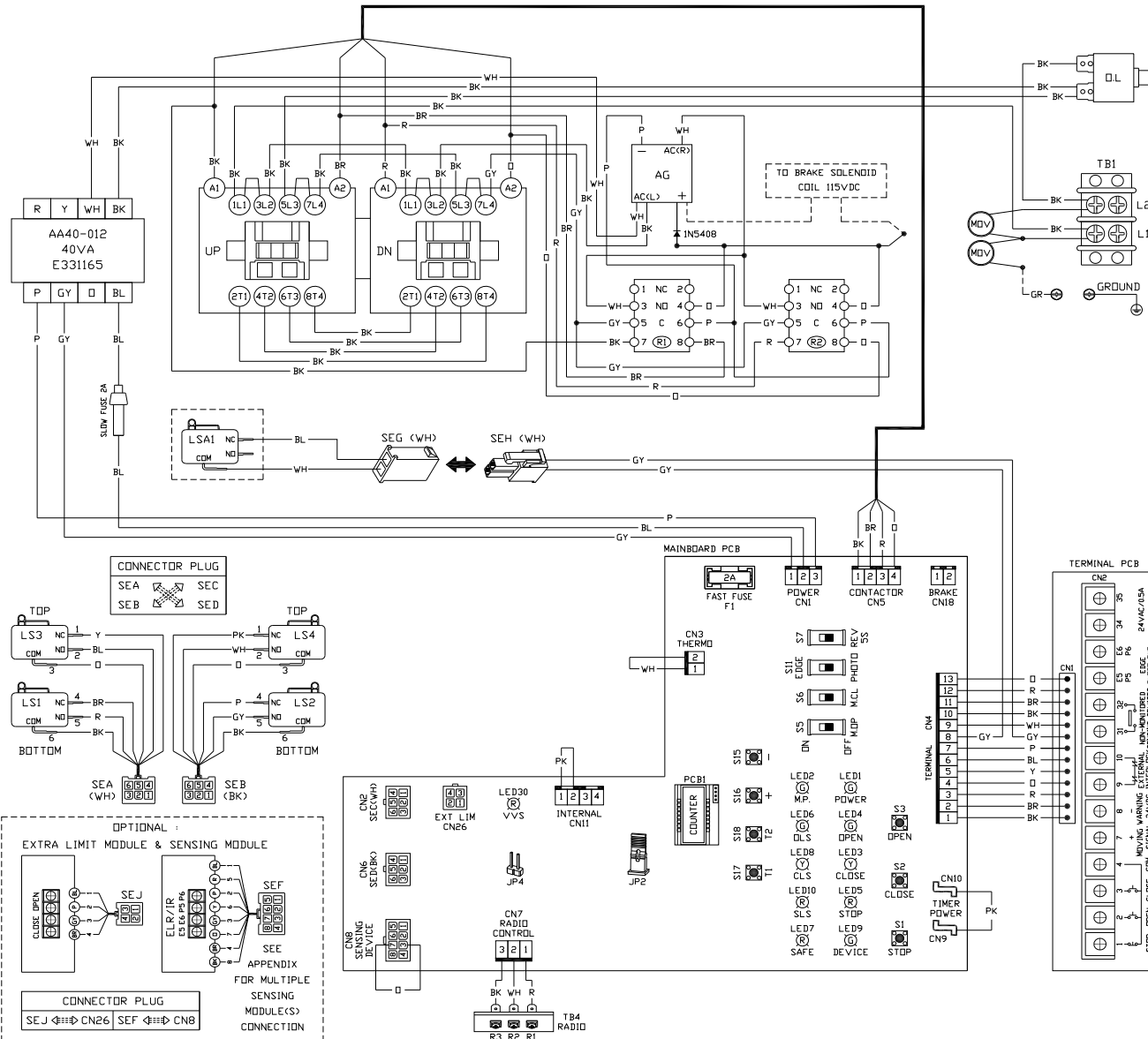

NOTES :

1. R1-OPEN RELAY (COIL 24VAC)
2. R2-CLOSE RELAY (COIL 24VAC)
3. MOV-TNR 14V 47JK
4. SEA-LS1 & LS3 MICROSWITCH CONNECTOR
5. SEB-LS2 & LS4 MICROSWITCH CONNECTOR
6. LSA1-PLUNGER SWITCH OF FUSIBLE LINK

MAINBOARD PCB :

1. SEC-OPEN CONTROL CONNECTOR
2. SED-CLOSE CONTROL CONNECTOR
3. CN8-SENSING MODULE CONNECTOR
4. CN9 & CN10-JUMP FOR ENABLING RECLOSE TIMER
5. CN26-OPTIONAL EXTRA OPEN AND CLOSE LIMITS CONNECTOR
6. S5-MOMENTARY/CONSTANT PRESSURE OPEN
7. S6-MOMENTARY/CONSTANT PRESSURE CLOSE
8. S7-REVERSE TO OPEN LIMIT OR REVERSE 5 SEC.
9. S11-EDGE/PHOTO EYE SENSING DEVICE SELECTION
10. JP2-OPEN AND CLOSE WARNING SIGNAL (JUMPED)  
 REMOVE JUMPER FOR CLOSE WARNING SIGNAL ONLY.
11. JP4-RESERVED, INTERNAL USE.

TERMINAL PCB - CN2 :

- 1 CONTROL STATION-STOP
  - 2 CONTROL STATION-OPEN
  - 3 CONTROL STATION-CLOSE
  - 4 CONTROL STATION-COMMON
- 7&8 DDDR MOVING WARNING SIGNAL 24VDC  
 9&10 EXTERNAL INTERLOCK  
 11&12 NON-MONITORED SENSING DEVICES (N.O. DRY CONTACT)  
 E5&E6/P5&P6 SENSING DEVICE CONNECTION  
 34&35 24VAC POWER, MAX 0.5A

115V 1 PHASE  
 MOTOR CONNECTION

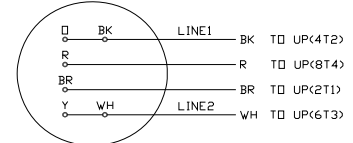

2017.06.09



FGH 230V 1 PHASE 50/60HZ LH (FGEP BOARD)  
 (60HZ FOR FGH 3321EP, 5021EP, 7521EP, 10021EP, 15021EP, 20021EP)  
 (50HZ FOR FGH 5025EP, 7525EP, 10025EP, 15025EP, 20025EP)

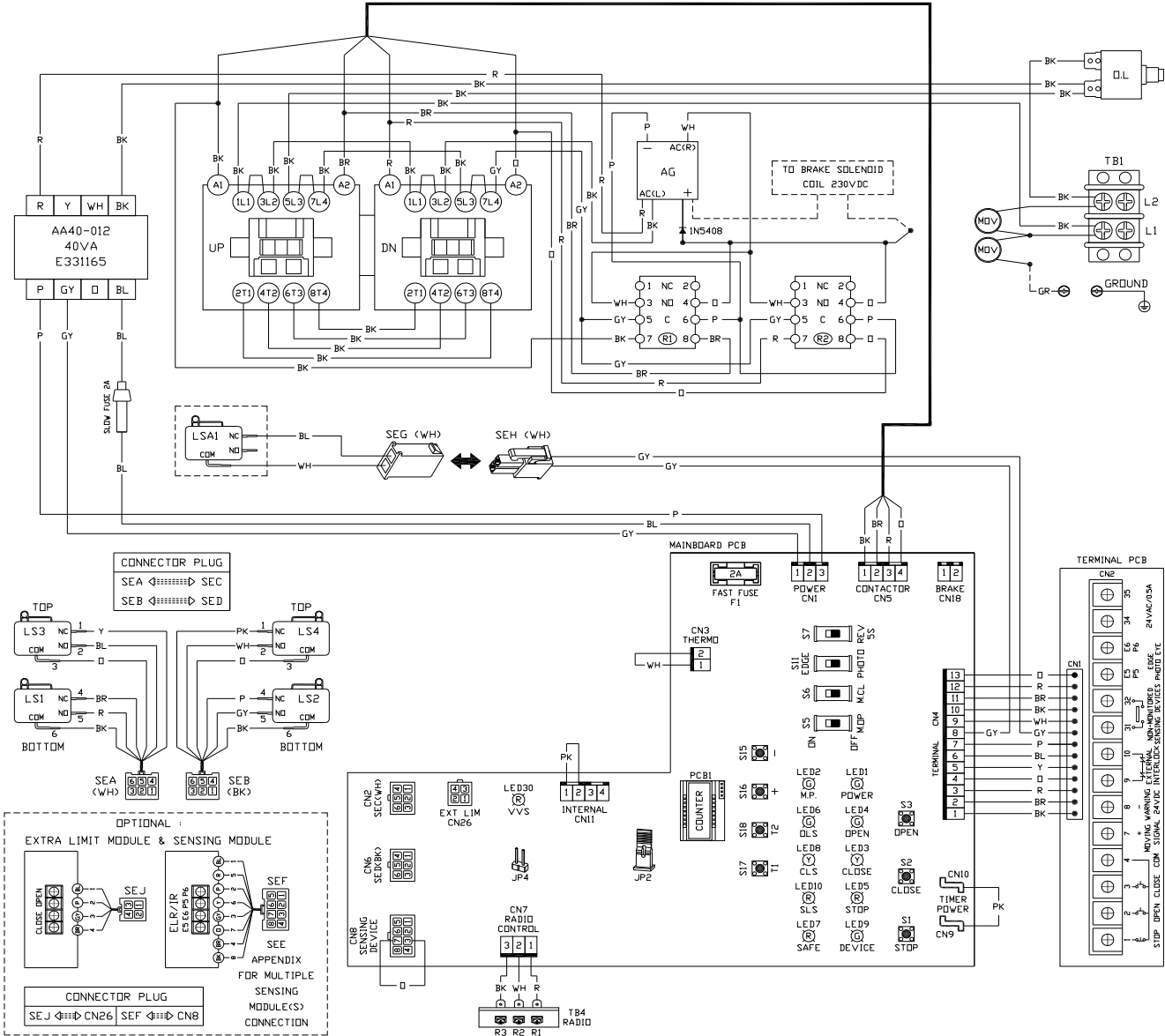

EE 708EP L  
V3.08

- NOTES :
1. R1-OPEN RELAY (COIL 24VAC)
  2. R2-CLOSE RELAY (COIL 24VAC)
  3. MOV-TNR 14V 471K
  4. SEA-LS1 & LS3 MICROSWITCH CONNECTOR
  5. SEB-LS2 & LS4 MICROSWITCH CONNECTOR
  6. LSA1-PLUNGER SWITCH OF FUSIBLE LINK

- MAINBOARD PCB :
1. SEC-OPEN CONTROL CONNECTOR
  2. SEC-CLOSE CONTROL CONNECTOR
  3. CN8-SENSING MODULE CONNECTOR
  4. CN9 & CN10-JUMP FOR ENABLING RECLOSE TIMER
  5. CN26-OPTIONAL EXTRA OPEN AND CLOSE LIMITS CONNECTOR
  6. S5-MOMENTARY/CONSTANT PRESSURE OPEN
  7. S6-MOMENTARY/CONSTANT PRESSURE CLOSE
  8. S7-REVERSE TO OPEN LIMIT OR REVERSE S SEC.
  9. S11-EDGE/PHOTO EYE SENSING DEVICE SELECTION
  10. JP2-OPEN AND CLOSE WARNING SIGNAL (JUMPED)  
REMOVE JUMPER FOR CLOSE WARNING SIGNAL ONLY.
  11. JP4-RESERVED, INTERNAL USE.

- TERMINAL PCB - CN2 :
- 1 CONTROL STATION-STOP
  - 2 CONTROL STATION-OPEN
  - 3 CONTROL STATION-CLOSE
  - 4 CONTROL STATION-COMMON
- 7&8 DOOR MOVING WARNING SIGNAL 24VDC  
 9&10 EXTERNAL INTERLOCK  
 31&32 NON-MONITORED SENSING DEVICES (N.O. DRY CONTACT)  
 E5&E6/P5&P6 SENSING DEVICE CONNECTION  
 34&35 24VAC POWER, MAX 0.5A

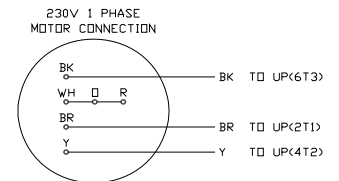

2017.06.09

FGH 230V 1 PHASE 50/60HZ RH (FGEP BOARD)  
 (60HZ FOR FGH 3321EP, 5021EP, 7521EP, 10021EP, 15021EP, 20021EP)  
 (50HZ FOR FGH 5025EP, 7525EP, 10025EP, 15025EP, 20025EP)

EE 708EP R  
V3.08

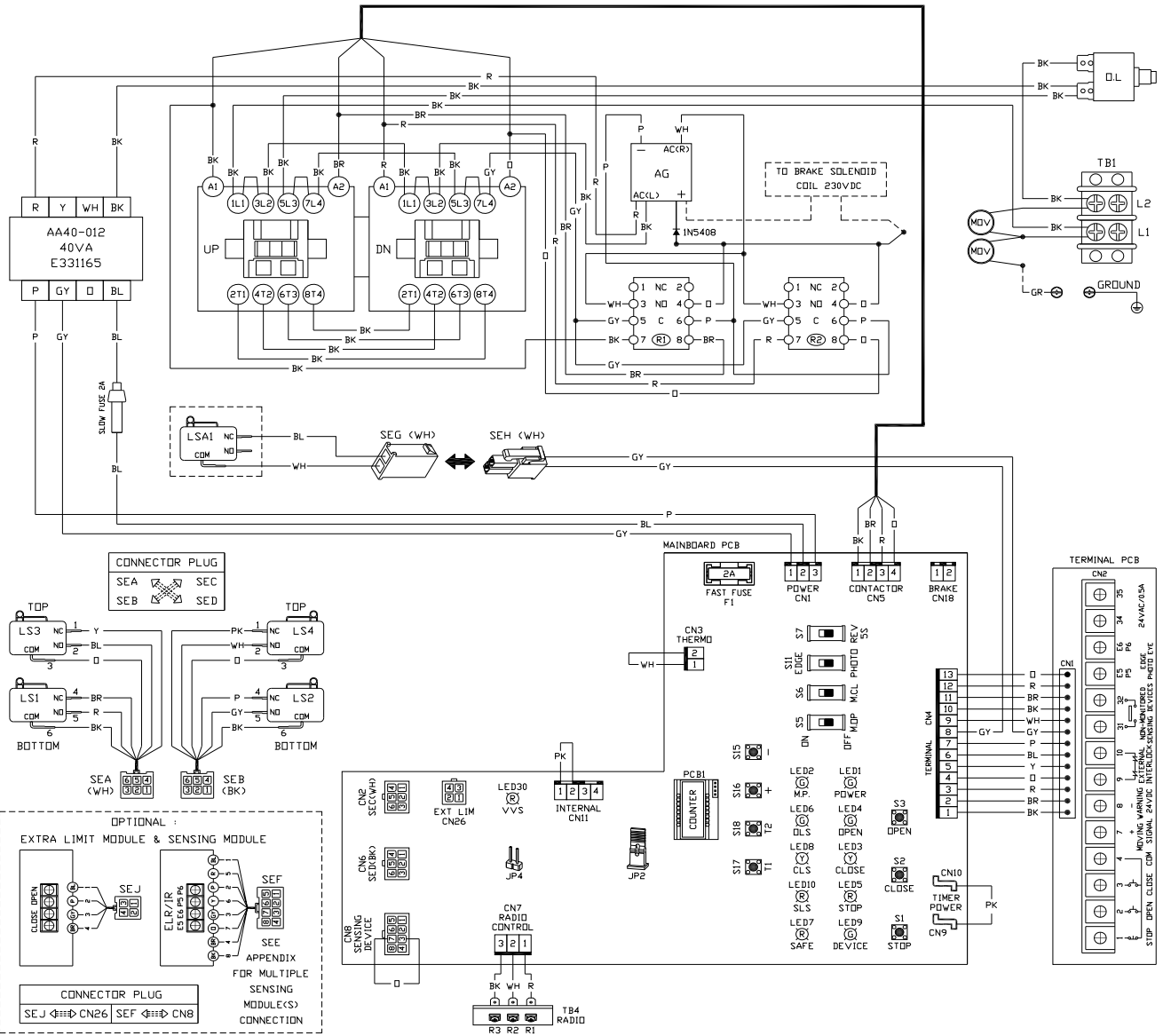

- NOTES :
1. R1-OPEN RELAY (COIL 24VAC)
  2. R2-CLOSE RELAY (COIL 24VAC)
  3. MOV-TNR 14V 471K
  4. SEA-LS1 & LS3 MICROSWITCH CONNECTOR
  5. SEB-LS2 & LS4 MICROSWITCH CONNECTOR
  6. LSA1-PLUNGER SWITCH OF FUSIBLE LINK

- MAINBOARD PCB :
1. SEC-OPEN CTRL CONTROL CONNECTOR
  2. SED-CLOSE CTRL CONTROL CONNECTOR
  3. CN8-SENSING MODULE CONNECTOR
  4. CN9 & CN10-JUMP FOR ENABLING RECLOSE TIMER
  5. CN26-OPTIONAL EXTRA OPEN AND CLOSE LIMITS CONNECTOR
  6. S5-MOMENTARY/CONSTANT PRESSURE OPEN
  7. S6-MOMENTARY/CONSTANT PRESSURE CLOSE
  8. S7-REVERSE TO OPEN LIMIT OR REVERSE 5 SEC.
  9. S11-EDGE/PHOTO EYE SENSING DEVICE SELECTION
  10. JP2-OPEN AND CLOSE WARNING SIGNAL (JUMPED)  
REMOVE JUMPER FOR CLOSE WARNING SIGNAL ONLY.
  11. JP4-RESERVED, INTERNAL USE.

- TERMINAL PCB - CN2 :
- 1 CONTROL STATION-STOP
  - 2 CONTROL STATION-OPEN
  - 3 CONTROL STATION-CLOSE
  - 4 CONTROL STATION-COMMON
- 7&8 DOOR MOVING WARNING SIGNAL 24VDC  
 9&10 EXTERNAL INTERLOCK  
 31&32 NON-MONITORED SENSING DEVICES (N.O. DRY CONTACT)  
 E5&E6/P5&P6 SENSING DEVICE CONNECTION  
 34&35 24VAC POWER, MAX 0.5A

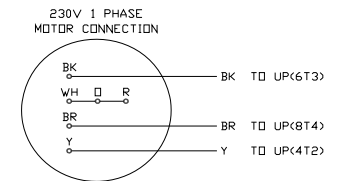

2017.06.09



**NOTE:**  
 FOR 208V INPUT POWER  
 • REMOVE RED WIRE CONNECTOR AND THEN CONNECT TO YELLOW WIRE.  
 • PROPERLY INSULATED THE RED WIRE.

FGH 208V/230V 3 PHASE 50/60HZ RH (FGEP BOARD)  
 (FOR FGH 3323EP, 5023EP, 7523EP, 10023EP, 15023EP, 20023EP)

EE 808EP R  
 V3.08

- NOTES :
1. R1-OPEN RELAY (COIL 24VAC)
  2. R2-CLOSE RELAY (COIL 24VAC)
  3. MOV-TNR 14V 471K
  4. SEA-LS1 & LS3 MICROSWITCH CONNECTOR
  5. SEB-LS2 & LS4 MICROSWITCH CONNECTOR
  6. LSA1-PLUNGER SWITCH OF FUSIBLE LINK

- MAINBOARD PCB :
1. SEC-OPEN CONTROL CONNECTOR
  2. SEC-CLOSE CONTROL CONNECTOR
  3. CN8-SENSING MODULE CONNECTOR
  4. CN9 & CN10-JUMP FOR ENABLING RECLOSE TIMER
  5. CN26-OPTIONAL EXTRA OPEN AND CLOSE LIMITS CONNECTOR
  6. S5-MOMENTARY/CONSTANT PRESSURE OPEN
  7. S6-MOMENTARY/CONSTANT PRESSURE CLOSE
  8. S7-REVERSE TO OPEN LIMIT OR REVERSE 5 SEC.
  9. S11-EDGE/PHOTO EYE SENSING DEVICE SELECTION
  10. JP2-OPEN AND CLOSE WARNING SIGNAL (JUMPED)  
 REMOVE JUMPER FOR CLOSE WARNING SIGNAL ONLY.
  11. JP4-RESERVED, INTERNAL USE.

- TERMINAL PCB - CN2 :
- 1 CONTROL STATION-STOP
  - 2 CONTROL STATION-OPEN
  - 3 CONTROL STATION-CLOSE
  - 4 CONTROL STATION-COMMON
- 7&8 DOOR MOVING WARNING SIGNAL 24VDC  
 9&10 EXTERNAL INTERLOCK  
 31&32 NON-MONITORED SENSING DEVICES (N.D. DRY CONTACT)  
 E5&E6/P5&P6 SENSING DEVICE CONNECTION  
 34&35 24VAC POWER, MAX 0.5A

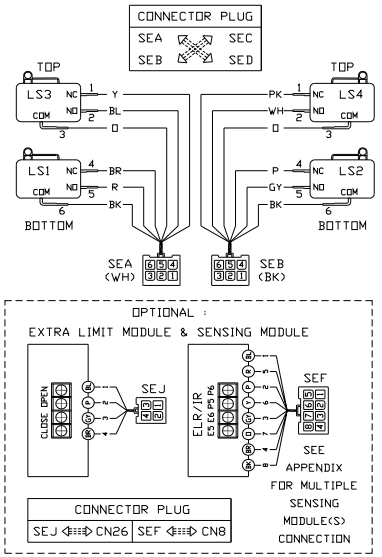
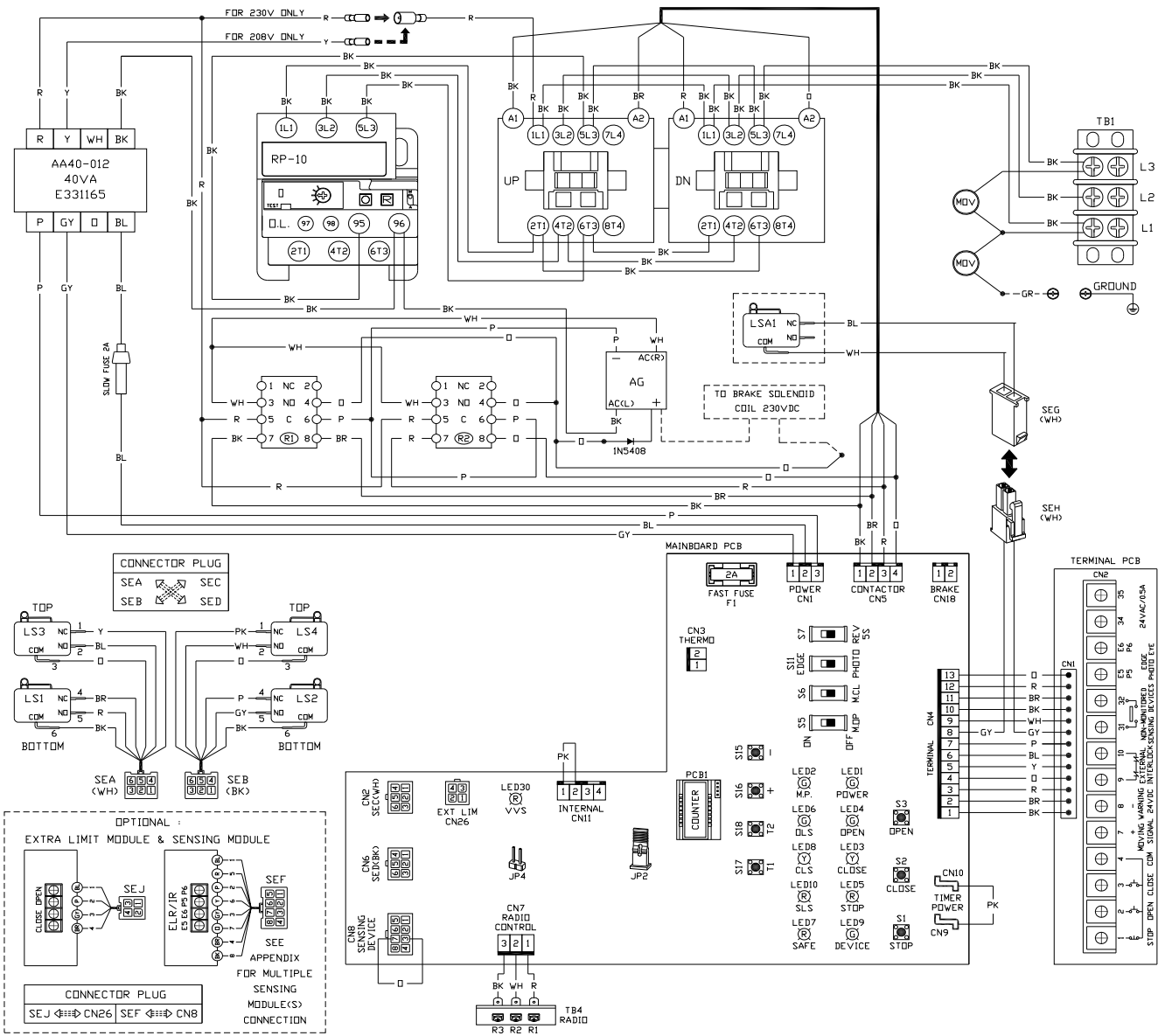
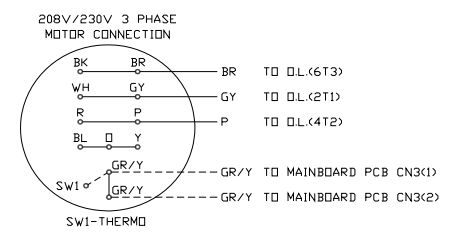

FGH 460V 3 PHASE 50/60HZ LH (FGEP BOARD)  
 (FOR FGH 3343EP, 5043EP, 7543EP, 10043EP, 15043EP, 20043EP)

EE 908EP L  
 V3.08

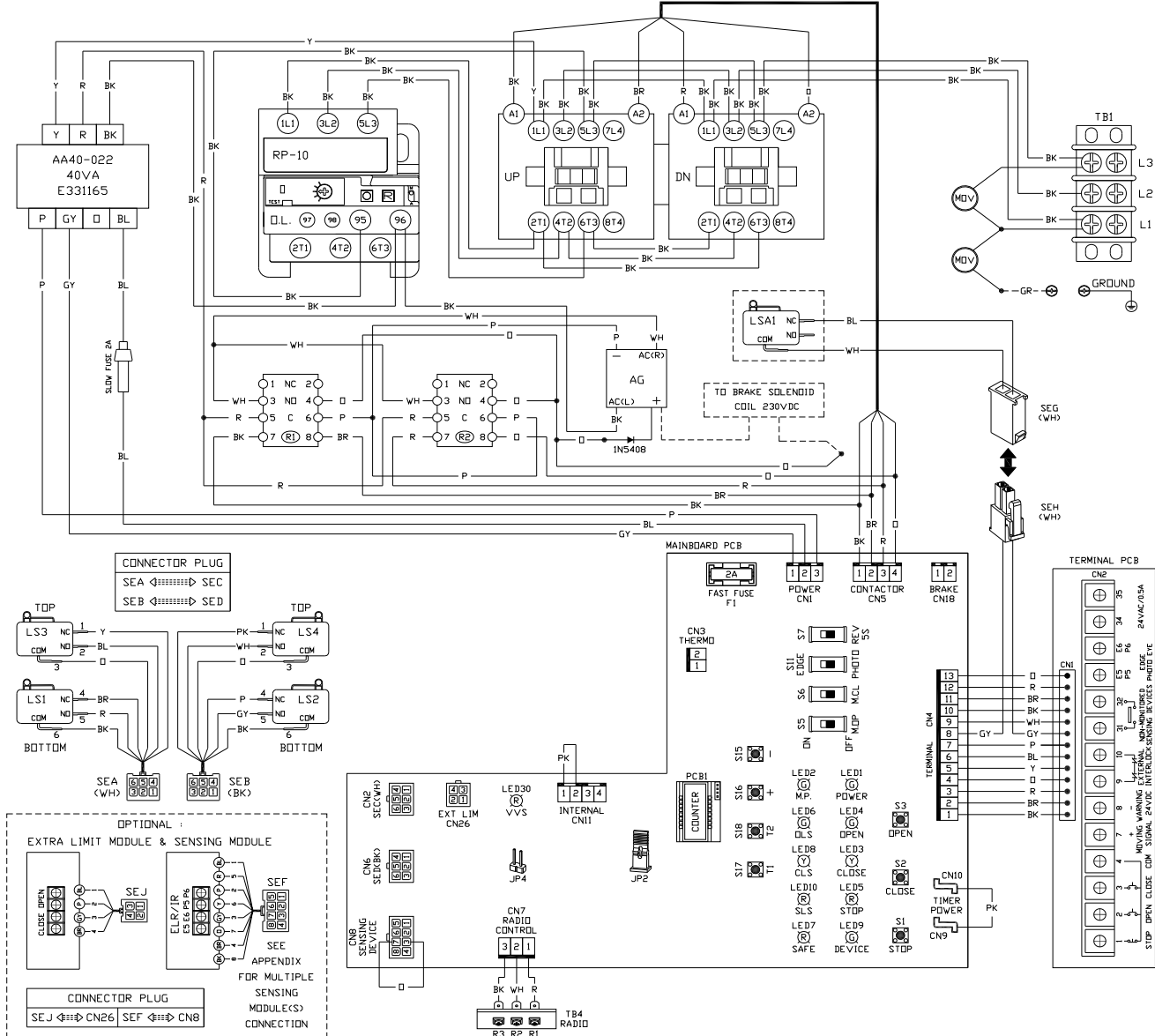

- NOTES :
1. R1-OPEN RELAY (COIL 24VAC)
  2. R2-CLOSE RELAY (COIL 24VAC)
  3. MOV-TNR 14V 102K OR 15G 102K
  4. SEA-LS1 & LS3 MICROSWITCH CONNECTOR
  5. SEB-LS2 & LS4 MICROSWITCH CONNECTOR
  6. LSA1-PLUNGER SWITCH OF FUSIBLE LINK

- MAINBOARD PCB :
1. SEC-OPEN CONTROL CONNECTOR
  2. SED-CLOSE CONTROL CONNECTOR
  3. CN8-SENSING MODULE CONNECTOR
  4. CN9 & CN10-JUMP FOR ENABLING RECLOSE TIMER
  5. CN26-OPTIONAL EXTRA OPEN AND CLOSE LIMITS CONNECTOR
  6. S5-MOMENTARY/CONSTANT PRESSURE OPEN
  7. S6-MOMENTARY/CONSTANT PRESSURE CLOSE
  8. S7-REVERSE TO OPEN LIMIT OR REVERSE 5 SEC.
  9. S11-EDGE/PHOTO EYE SENSING DEVICE SELECTION
  10. JP2-OPEN AND CLOSE WARNING SIGNAL (JUMPED)  
 REMOVE JUMPER FOR CLOSE WARNING SIGNAL ONLY.
  11. JP4-RESERVED, INTERNAL USE.

- TERMINAL PCB - CN2 :
- 1 CONTROL STATION-STOP
  - 2 CONTROL STATION-OPEN
  - 3 CONTROL STATION-CLOSE
  - 4 CONTROL STATION-COMMON
  - 7&8 DOOR MOVING WARNING SIGNAL 24VDC
  - 9&10 EXTERNAL INTERLOCK
  - 31&32 NON-MONITORED SENSING DEVICES (N.O. DRY CONTACT)
  - E5&E6/P5&P6 SENSING DEVICE CONNECTION
  - 34&35 24VAC POWER, MAX 0.5A

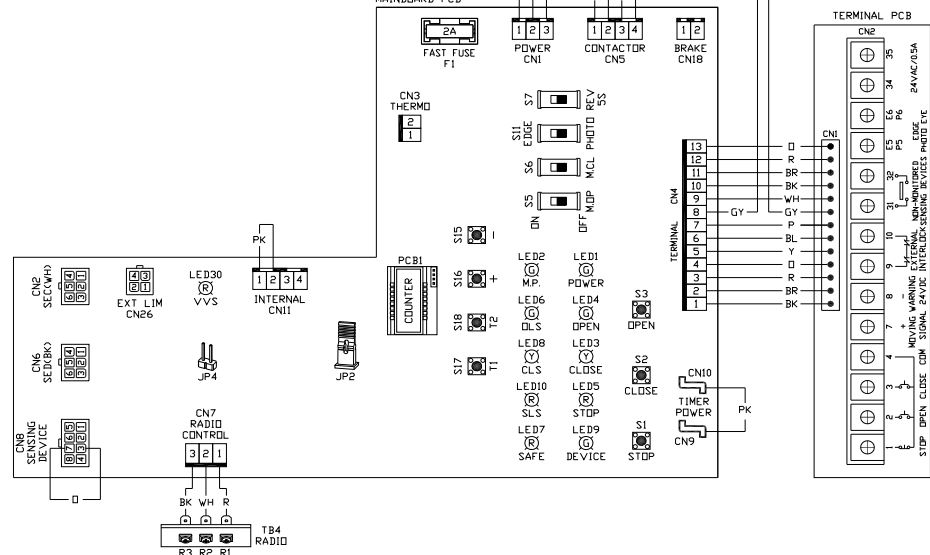
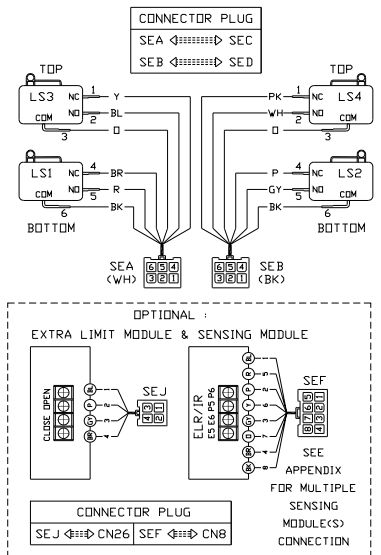
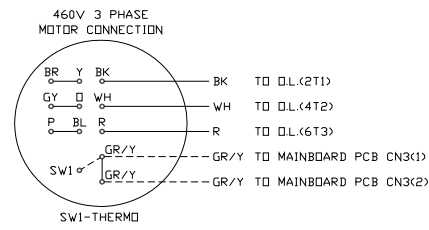

FGH 460V 3 PHASE 50/60HZ RH (FGEP BOARD)  
 (FOR FGH 3343EP, 5043EP, 7543EP, 10043EP, 15043EP, 20043EP)

EE 908EP R  
 V3.08

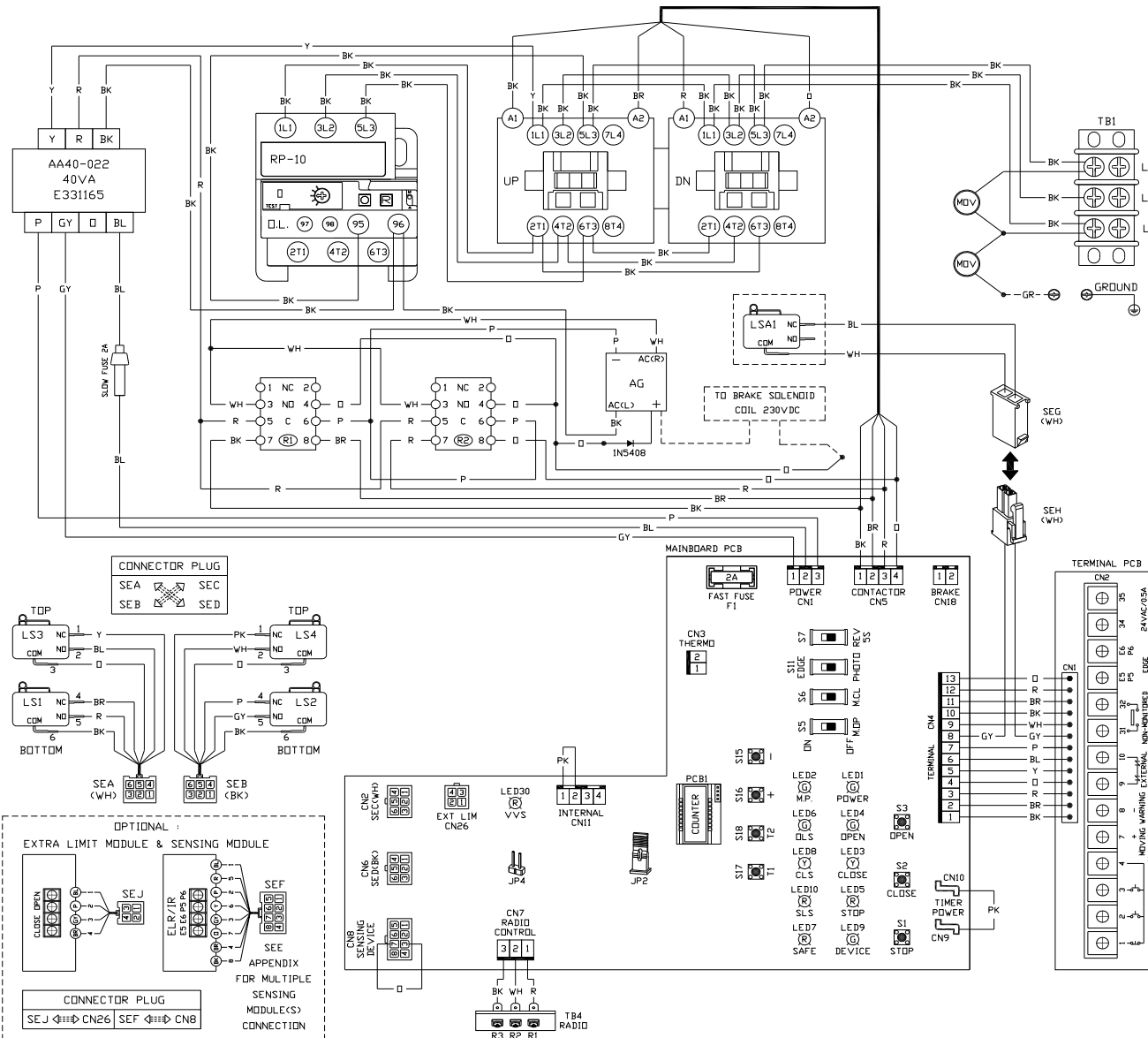

NOTES :

1. R1-OPEN RELAY (COIL 24VAC)
2. R2-CLOSE RELAY (COIL 24VAC)
3. MOV-TNR 14V 102K DR 15G 102K
4. SEA-LS1 & LS3 MICROSWITCH CONNECTOR
5. SEB-LS2 & LS4 MICROSWITCH CONNECTOR
6. LSA1-PLUNGER SWITCH OF FUSIBLE LINK

MAINBOARD PCB :

1. SEC-OPEN CONTROL CONNECTOR
2. SEC-CLOSE CONTROL CONNECTOR
3. CN8-SENSING MODULE CONNECTOR
4. CN9 & CN10-JUMP FOR ENABLING RECLOSE
5. CN26-OPTIONAL EXTRA OPEN AND CLOSE LIMITS CONNECTOR
6. S5-MOMENTARY/CONSTANT PRESSURE OPEN
7. S6-MOMENTARY/CONSTANT PRESSURE CLOSE
8. S7-REVERSE TO OPEN LIMIT OR REVERSE 5 SEC.
9. S11-EDGE/PHOTO EYE SENSING DEVICE SELECTION
10. JP2-OPEN AND CLOSE WARNING SIGNAL (JUMPED)  
 REMOVE JUMPER FOR CLOSE WARNING SIGNAL ONLY.
11. JP4-RESERVED, INTERNAL USE.

TERMINAL PCB - CN2 :

- 1 CONTROL STATION-STOP
- 2 CONTROL STATION-OPEN
- 3 CONTROL STATION-CLOSE
- 4 CONTROL STATION-COMMON
- 7&8 DDDR MOVING WARNING SIGNAL 24VDC
- 9&10 EXTERNAL INTERLOCK
- 31&32 NON-MONITORED SENSING DEVICES (N.O. DRY CONTACT)
- E5&E6/P5&P6 SENSING DEVICE CONNECTION
- 34&35 24VAC POWER, MAX 0.5A

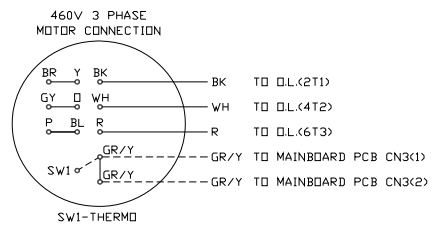

2017.06.09

FGH 575V 3 PHASE 60HZ LH (FGEP BOARD)  
 (FOR FGH 3353EP, 5053EP, 7553EP, 10053EP, 15053EP, 20053EP)

EE 508EP L  
 V3.08

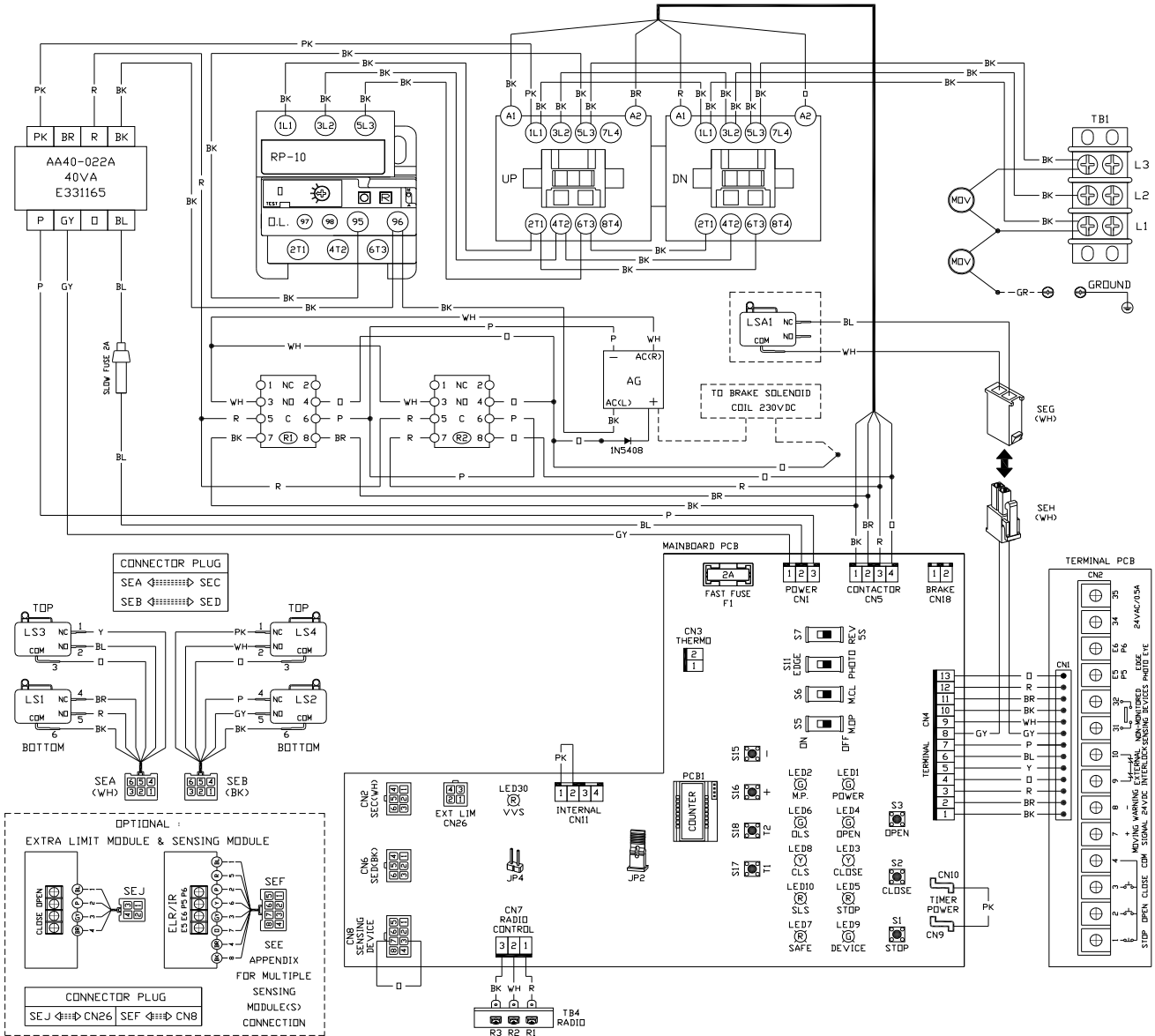

- NOTES :
1. R1-OPEN RELAY (COIL 24VAC)
  2. R2-CLOSE RELAY (COIL 24VAC)
  3. MOV-TNR 14V 122K DR 15G 122K
  4. SEA-LS1 & LS3 MICROSWITCH CONNECTOR
  5. SEB-LS2 & LS4 MICROSWITCH CONNECTOR
  6. LSA1-PLUNGER SWITCH OF FUSIBLE LINK

- MAINBOARD PCB :
1. SEC-OPEN CONTROL CONNECTOR
  2. SEC-CLOSE CONTROL CONNECTOR
  3. CN8-SENSING MODULE CONNECTOR
  4. CN9 & CN10-JUMP FOR ENABLING RECLOSE LIMITS
  5. CN26-OPTIONAL EXTRA OPEN AND CLOSE LIMITS CONNECTOR
  6. S5-MOMENTARY/CONSTANT PRESSURE OPEN
  7. S6-MOMENTARY/CONSTANT PRESSURE CLOSE
  8. S7-REVERSE TO OPEN LIMIT OR REVERSE 5 SEC.
  9. S11-EDGE/PHOTO EYE SENSING DEVICE SELECTION
  10. JP2-OPEN AND CLOSE WARNING SIGNAL (JUMPED)  
 REMOVE JUMPER FOR CLOSE WARNING SIGNAL ONLY.
  11. JP4-RESERVED, INTERNAL USE.

- TERMINAL PCB - CN2 :
1. CTRLNL STATION-STOP
  2. CTRLNL STATION-OPEN
  3. CTRLNL STATION-CLOSE
  4. CONTROL STATION-COMMON
- 78.8 DDR MOVING WARNING SIGNAL 24VDC  
 98.10 EXTERNAL INTERLOCK  
 31&32 NON-MONITORED SENSING DEVICES (N.O. DRY CONTACT)  
 E5&E6/PS&P6 SENSING DEVICE CONNECTION  
 34&35 24VAC POWER, MAX 0.5A

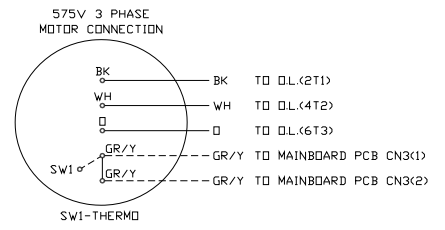

2017.06.09

FGH 575V 3 PHASE 60HZ RH (FGEP BOARD)  
 (FOR FGH 3353EP, 5053EP, 7553EP, 10053EP, 15053EP, 20053EP)

EE 508EP R  
 V3.08

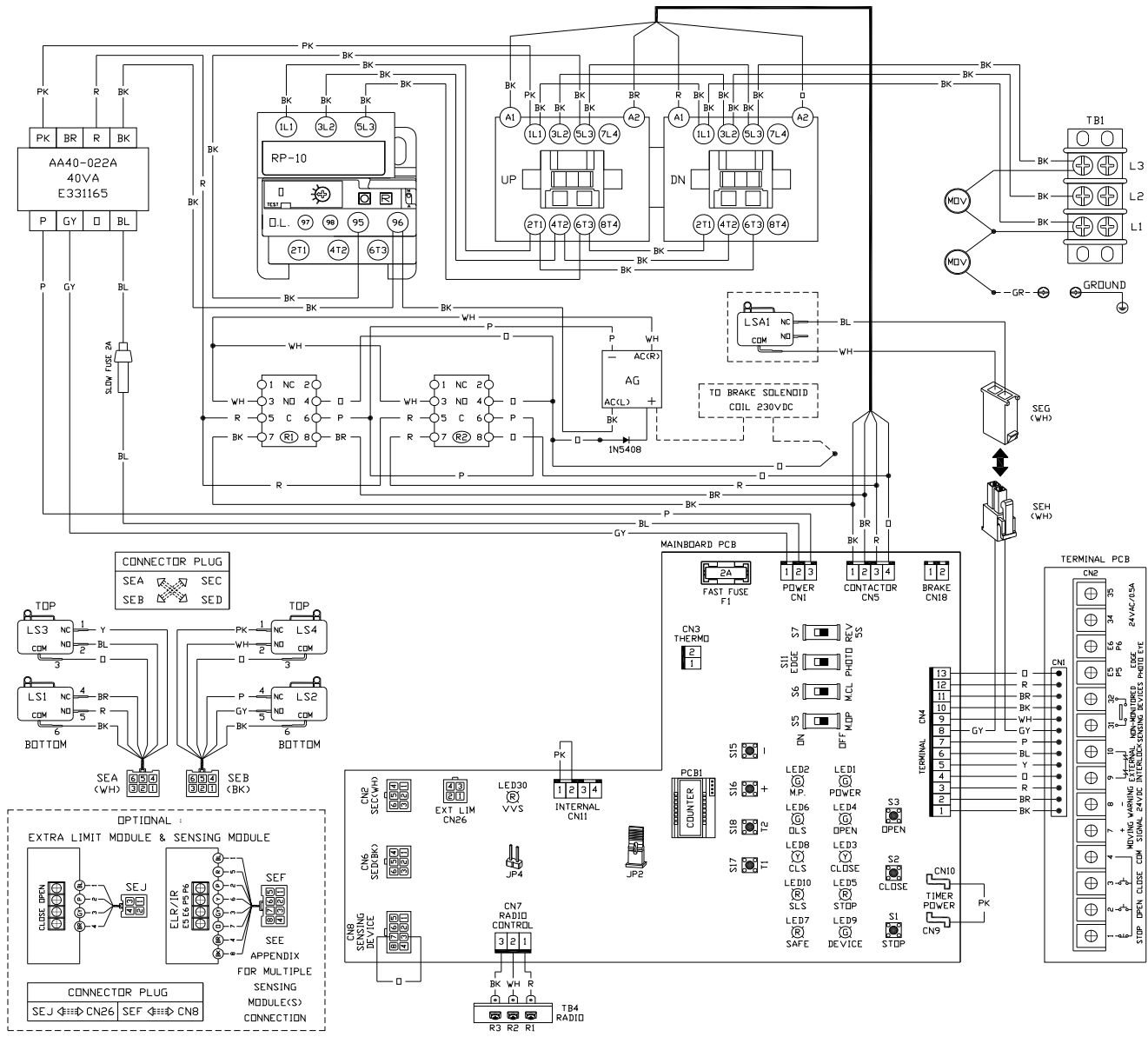

- NOTES :
1. R1-OPEN RELAY (COIL 24VAC)
  2. R2-CLOSE RELAY (COIL 24VAC)
  3. MOV-TNR 14V 122K DR 15G 122K
  4. SEA-LS1 & LS3 MICROSWITCH CONNECTOR
  5. SEB-LS2 & LS4 MICROSWITCH CONNECTOR
  6. LSA1-PLUNGER SWITCH OF FUSIBLE LINK

- MAINBOARD PCB :
1. SEC-OPEN CONTROL CONNECTOR
  2. SEC-CLOSE CONTROL CONNECTOR
  3. CN8-SENSING MODULE CONNECTOR
  4. CN9 & CN10-JUMP FOR ENABLING RECLOSE TIMER
  5. CN26-OPTIONAL EXTRA OPEN AND CLOSE LIMITS CONNECTOR
  6. S5-MOMENTARY/CONSTANT PRESSURE OPEN
  7. S6-MOMENTARY/CONSTANT PRESSURE CLOSE
  8. S7-REVERSE TO OPEN LIMIT OR REVERSE 5 SEC.
  9. S11-EDGE/PHOTO EYE SENSING DEVICE SELECTION
  10. JP2-OPEN AND CLOSE WARNING SIGNAL (JUMPED)  
 REMOVE JUMPER FOR CLOSE WARNING SIGNAL ONLY.
  11. JP4-RESERVED, INTERNAL USE.

- TERMINAL PCB - CN2 :
- 1 CONTROL STATION-STOP
  - 2 CONTROL STATION-OPEN
  - 3 CONTROL STATION-CLOSE
  - 4 CONTROL STATION-COMMON
- 7&8 DOOR MOVING WARNING SIGNAL 24VDC  
 9&10 EXTERNAL INTERLOCK  
 31&32 NON-MONITORED SENSING DEVICES (N.D. DRY CONTACT)  
 E5&E6/P5&P6 SENSING DEVICE CONNECTION  
 34&35 24VAC POWER, MAX 0.5A

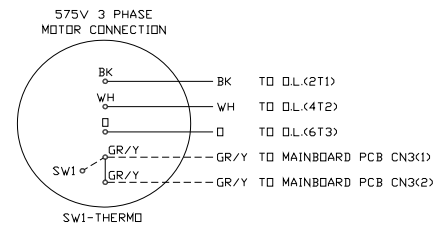

2017.06.09



## **IMPORTANT SAFETY INSTRUCTIONS**

### **WARNING –To reduce the risk of death or serious injury:**

1. READ AND FOLLOW ALL INSTRUCTIONS.
2. Never let children operate or play with door controls. Keep the remote control (when provided) away from children.
3. Personnel should keep away from a door in motion and keep the moving door in sight until it is completely closed or opened. NO ONE SHOULD CROSS THE PATH OF A MOVING DOOR.



Fire doors could close rapidly at any time and cause death or serious injury.

### **WARNING**

**Do NOT stand in the doorway.**

4. Test sensing devices at least once a month. Also test sensing devices after making any adjustments to the close limit. Failure to adjust the operator properly may cause death or serious injury.
5. For operators having an auxiliary release, use caution when using the release if the door is open. Weak or broken springs may cause the door to fall rapidly, causing death or serious injury.
6. KEEP DOORS PROPERLY OPERATING AND BALANCED. See door manufacturer's Operation and Maintenance Instructions. An improperly operating or unbalanced door could cause death or serious injury. Have trained door systems technicians make all necessary adjustments and repairs.
7. **SAVE THESE INSTRUCTIONS.**

## FUSIBLE LINK CONNECTIONS

- ❖ **REMOVE COTTER PIN FROM RELEASE ASSEMBLY AFTER INSTALLATION IS COMPLETE.**

Refer to the fire door installation instructions for connection of the release assembly or consult NFPA-80 and the authority having jurisdiction for fusible link location(s) and method.

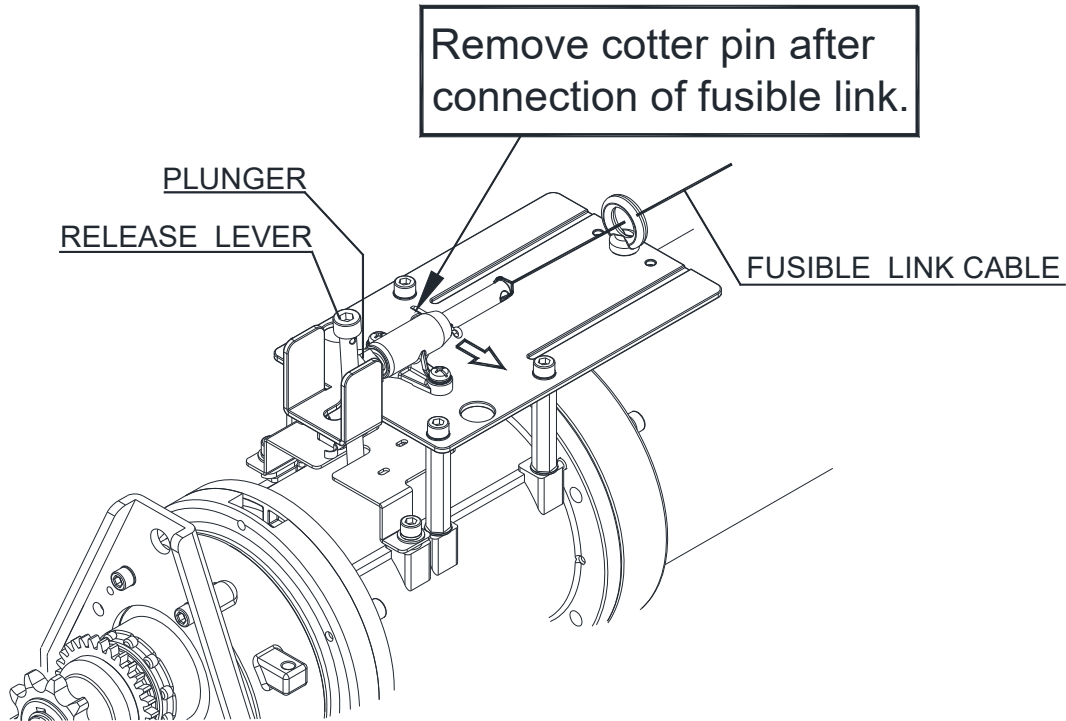

\* Illustration only, not drawn to scale. See product for actual details.

## **OPERATING INSTRUCTIONS**

1. If a 3-button control station is used to operate the door, push the “OPEN” button to open the door, push the “CLOSE” button to close the door, push the “STOP” button to stop movement of the door while opening or closing. With constant pressure close operation, removing pressure from the “CLOSE” button will also cause the door to stop.
2. If a key switch control station is used to operate the door, turn the key to the “OPEN” position to open the door, turn the key to the “CLOSE” position to close the door, push the “STOP” button to stop movement of the door while opening or closing. With constant pressure close operation, removing pressure from the “CLOSE” key position will cause the door to stop.
3. Door may also be operated by remote devices.

**IMPORTANT NOTE:** If one or more monitored sensing devices are installed, and determined by the operator to be not functioning properly, the door will either stay open, or re-open if closing. If this occurs, contact a trained door systems technician to make repairs. Until repairs can be made, the door can be opened and closed from the 3-button or key switch control station, but will require constant pressure on the close control to close the door.

## **EMERGENCY MANUAL OPERATION**

This operator has provisions for manually operating the door in case of emergency or power failure. This operator is equipped with an auxiliary chain hoist.

To operate the auxiliary chain hoist:

1. Remove the hand chain from the chain bag.
  2. Pull the hand chain to operate the door in the desired direction. (No clutch to engage)
- Put the hand chain back into the chain bag, before operating the door again electrically.



**WARNING**

**Turn off power to the operator before manually operating your door.**



**WARNING**

**Hand chain must be kept inside chain bag when operating electrically.**

## MAINTENANCE INSTRUCTIONS

The brake is a self-adjusting brake. It is maintenance free. The brake assembly requires no additional adjustments for its lifetime.

If an entrapment protection device is used, i.e. sensing edge or photoelectric sensors, please consult the manufacturer for maintenance instruction.



**Disconnect power supply to the operator before servicing.**

### **WARNING**

Check the following items at the intervals listed:

CHECK LIST	DESCRIPTION	EVERY 3 MONTHS	EVERY 6 MONTHS	EVERY 12 MONTHS
Drive Chain	Check for excessive slack. Check & adjust as required Lubricate.	●		
Sprockets	Check set screw tightness	●		
Fasteners	Check & tighten as required		●	
Bearings & Shafts	Check for wear & lubricate	●		
Drop-test	Inspect door, drop-test for proper operation and full closure per NFPA-80			●

- ❖ Do not lubricate motor. Motor bearings are rated for continuous operation.
- ❖ Inspect and service whenever a malfunction either door or operator is observed or suspected.
- ❖ Before servicing, always disconnect power supply to the operator.
- ❖ Replace fuses only with those of the same type and rating.
- ❖ All replacement parts must be obtained from the door manufacturer per NFPA-80.



### **WARNING**

**Do not place hands or tools in or near the operator when the power is connected or when testing control or sensing devices. Always disconnect power before servicing or adjusting the operator.**

# APPENDIX 1

## Multiple Sensing Devices Connection Instruction

Warning: Power OFF When Connecting.

QST-FG-EP-ADAPTER-3

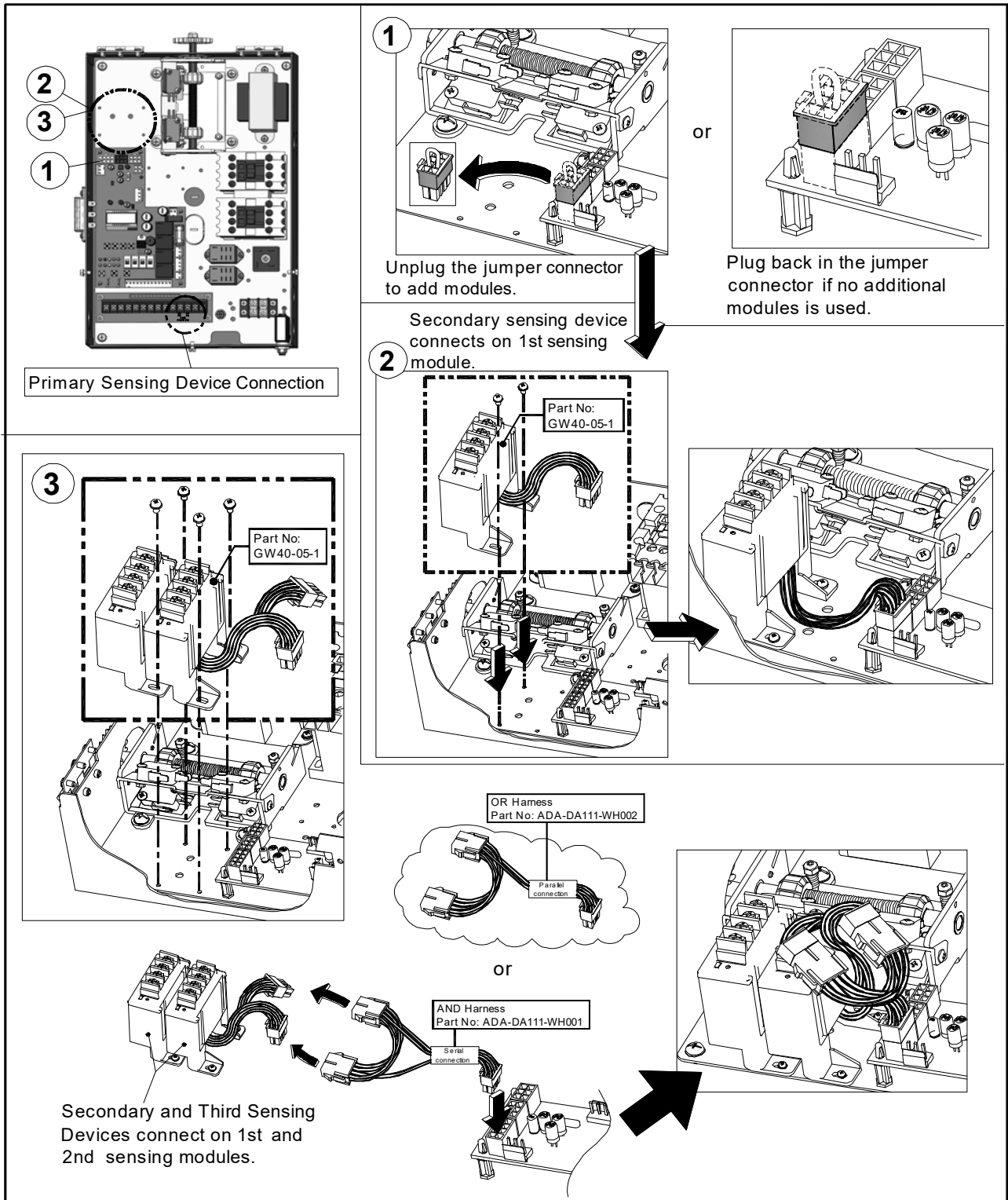

# APPENDIX 2

## Control Connections Diagrams

CCD-PCB-A01

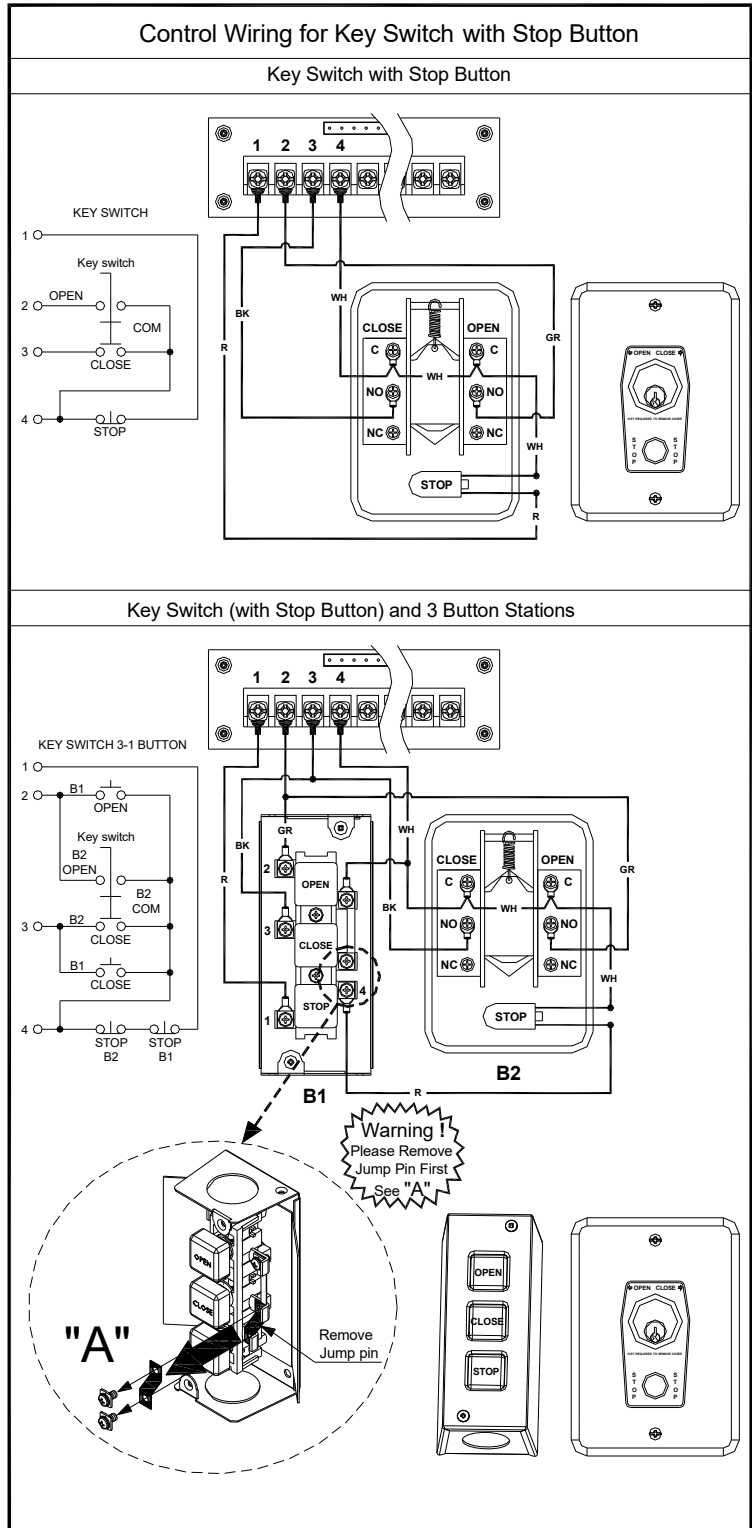
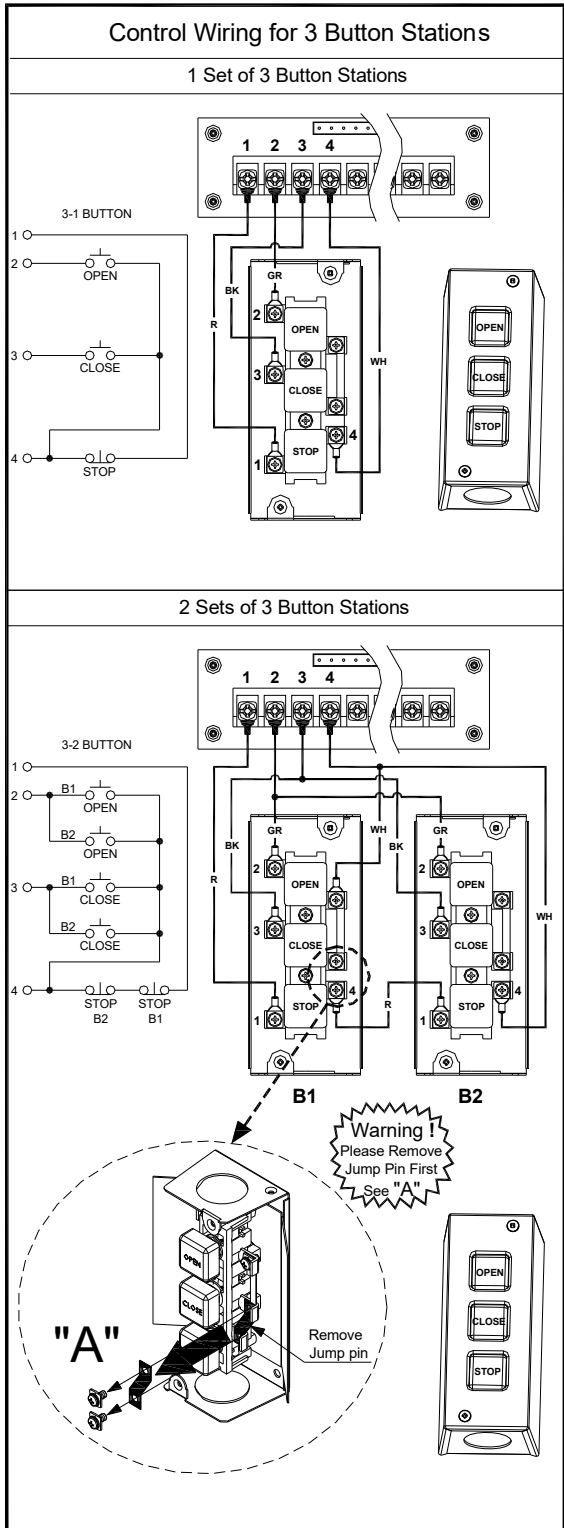

# APPENDIX 3

## Control Connections Diagrams

CCD-PCB-B02

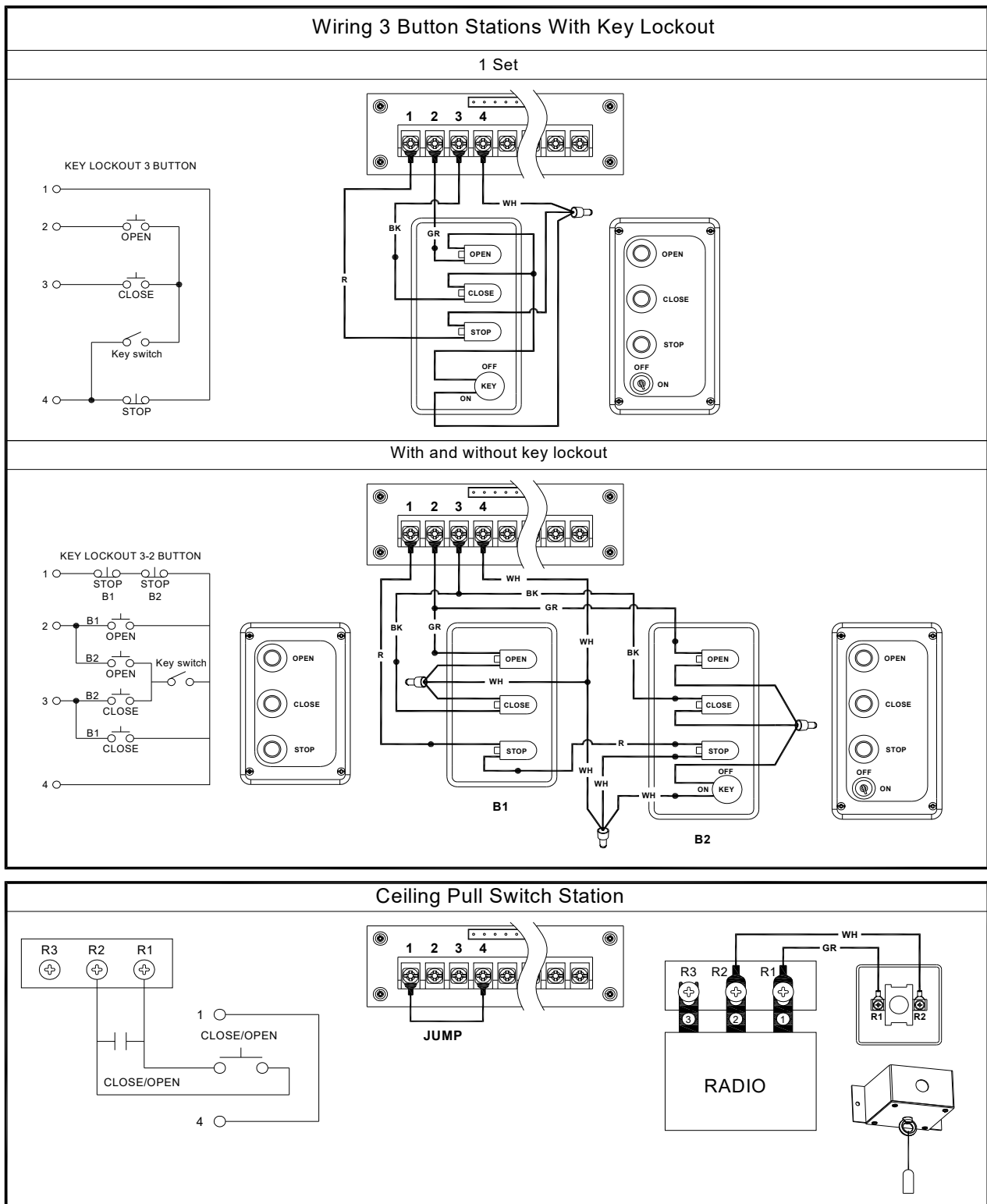

# APPENDIX 4

## EXTERNAL TIMER DEFEAT SWITCH CONNECTION-FGEP BOARD

ETDS-FGEP-002

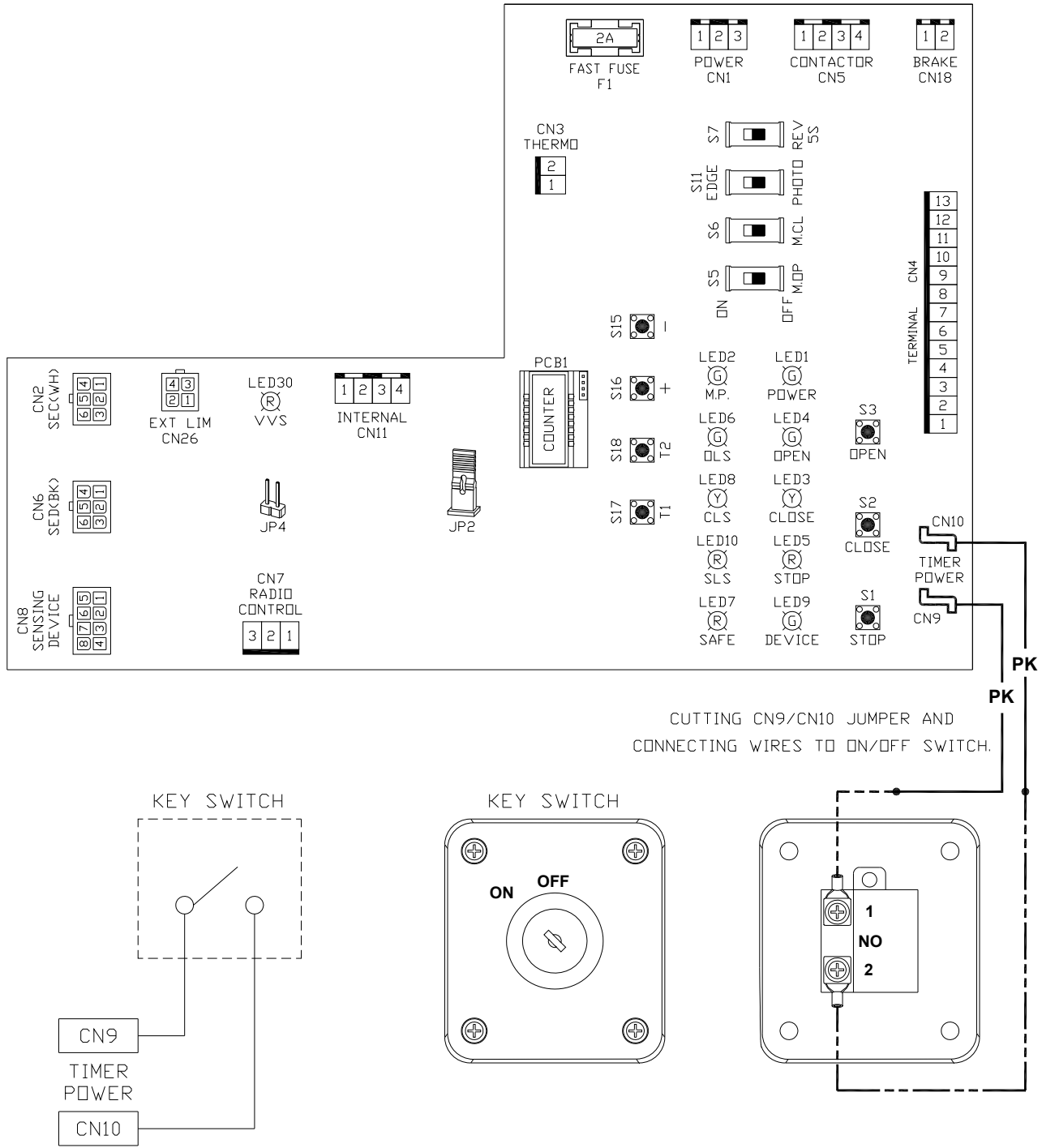



# APPENDIX 5

## Wiring Change Instruction from 230V to 208V 3 Phase Operator FGH EP Series

FGH-EP-3P-V02

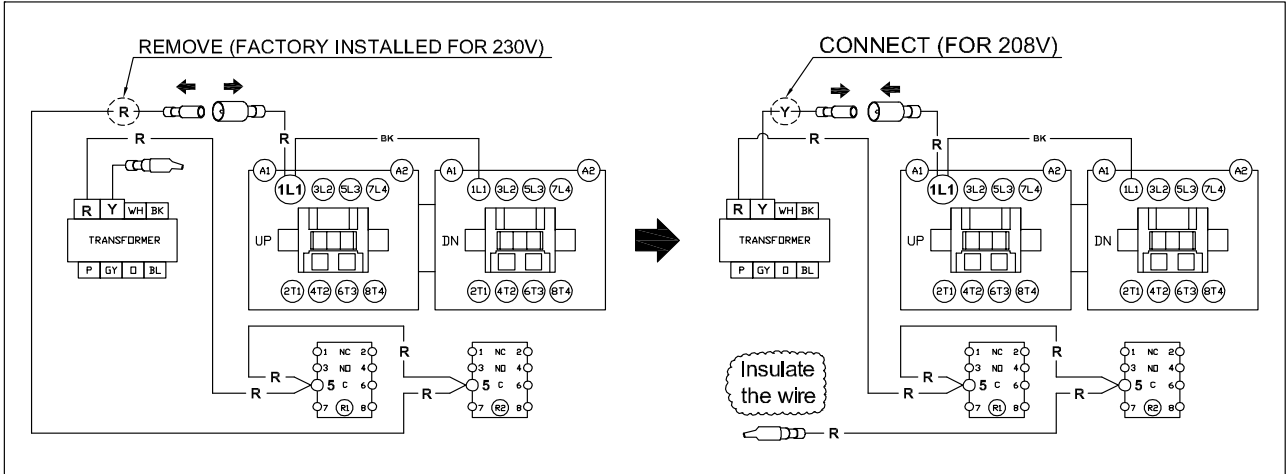

1. Unplug the red "230V" wire connector from the red "PWR" wire connector. Remove the insulating cap from the yellow "208V" wire connector.

2. Put the insulating cap on the red "230V" wire connector. Plug the yellow "208V" wire connector into the red "PWR" wire connector.

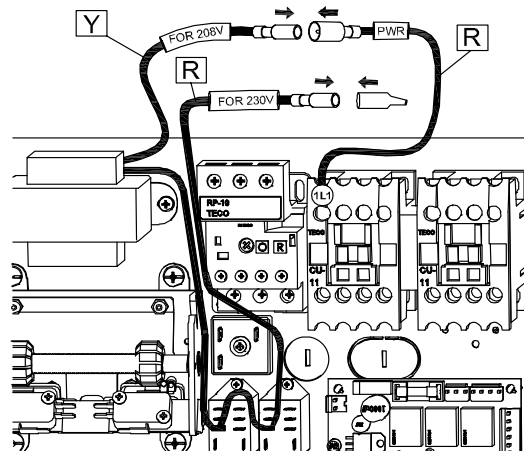
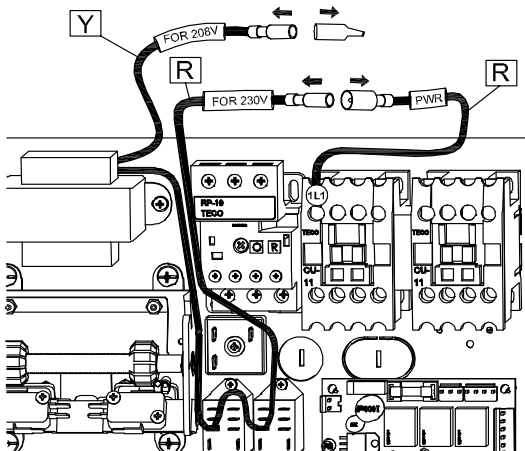

3. Completed.

