

INSULATED ROLLING DOOR

THERMISER MAX[®] - LOW U

Model ESD40



YOUR CLEAR CHOICE FOR ENERGY EFFICIENCY

U-FACTOR CERTIFIED THERMAL PERFORMANCE.

Energy savings and a more comfortable indoor environment are just a few of the benefits of Thermiser Max[®] - Low U. Its design features mineral wool insulation and a CPVC backer, offering a U-factor rating of 0.532 for the full assembly.* By undergoing third-party U-factor testing, Thermiser Max Low-U carries the industry's most accurate measurement of thermal performance.**

DESIGNED FOR RUGGED APPLICATIONS.

The Thermiser Max - Low U operates quietly and is ideal for exterior applications where climate control is critical, including warehouses and heavy equipment storage facilities. An insulated curtain, patented perimeter seal and thermally-broken guide construction work to minimize the speed of heat transferred through the door assembly.

CPVC backer, offers a U-factor rating of 0.532 for the full assembly.



MORE THAN MEETS THE EYE.

Along with its standout thermal performance, the Thermiser Max - Low U insulated door has another perk. The door carries a Sound Transmission Rating (STC) of up to 27 for the full assembly, offering control over exterior and interior noise levels. Doors meet ASHRAE[®] 90.12, IECC[®] 2021 and California's Title 24 air infiltration requirements with an independently tested value of less than 0.3 CFM/ft².

**Options such as windows, pass doors, etc. may impact U-factor. Contact factory for details on specific configurations.*

***Thermiser Max seal package required to meet.*

800.294.4358 | cooksondoor.com

CornellCookson, LLC. is an ISO 9001:2015 registered company
9.2024

Preferred door solutions.[®]
COOKSON

INSULATED ROLLING DOOR **THERMISER MAX® - LOW U Model ESD40**

STANDARD COMPONENT MATERIALS AND FINISHES

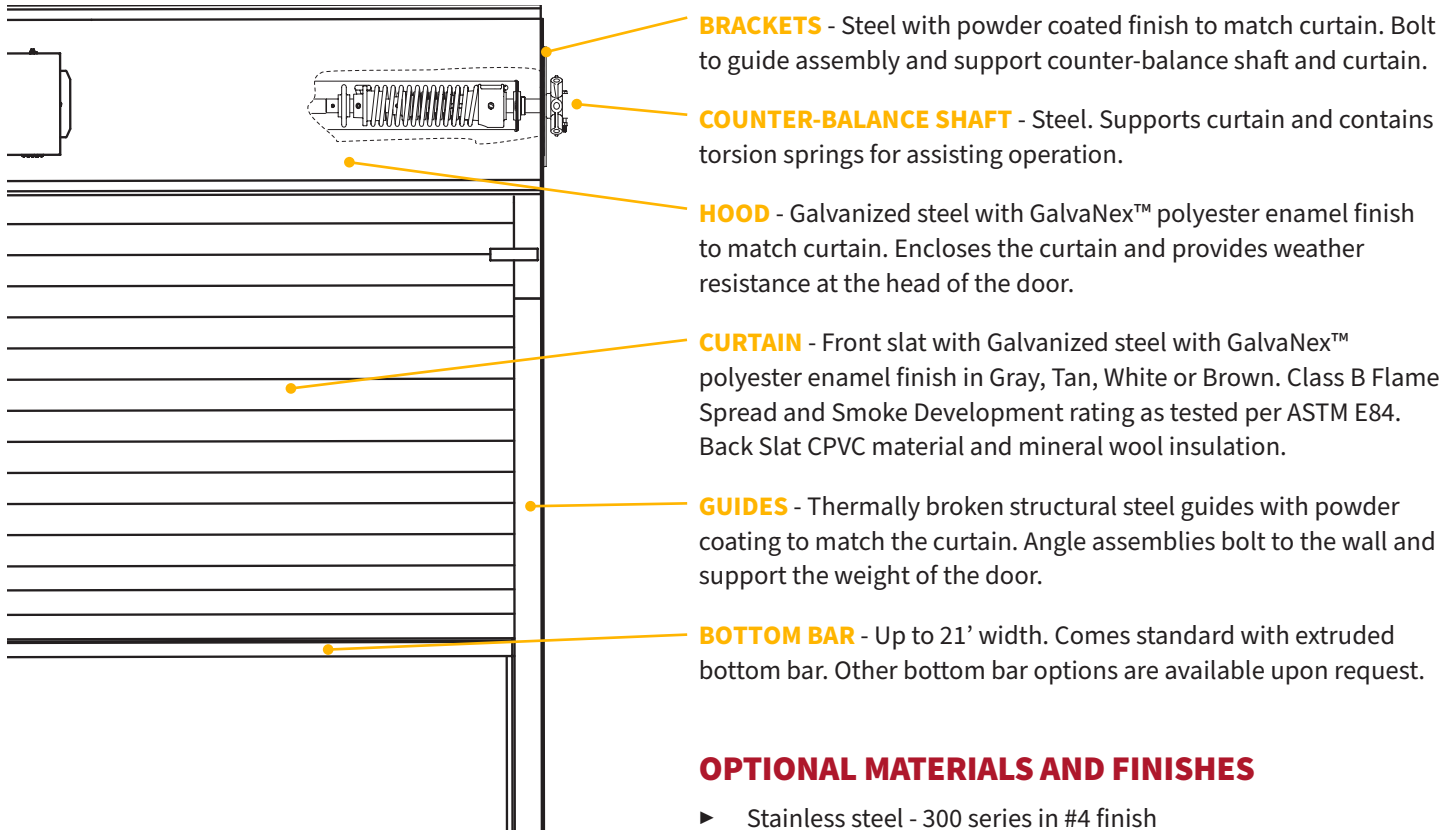

OPERATION AND STRUCTURAL REQUIREMENTS

Hand chain, hand crank and a variety of motor options are available.

This product is supported by a guide assembly attached to the jamb construction. No additional header support is required unless hood supports are mandated by a larger opening width. This door can be configured to offer a static wind load of up to 120 psf.

OPTIONAL MATERIALS AND FINISHES

- ▶ Stainless steel - 300 series in #4 finish
- ▶ SpectraShield® Powder Coating in more than 180 colors
- ▶ For a more durable finish, consider upgrading to our GalvaNex™ Ultra™ or SpectraShield® Ultra™ powder coat finish.
 - It is a polyester based textured wear resistant clear coat that provides increased resistance to corrosion of the curtain and improved durability against normal abrasion and scratching due to cycling.

Brackets, Guides and Bottom Bar

- ▶ Hot-dip galvanizing on steel components
- ▶ Zinc-enriched, corrosion-resistant powder coating in Gray

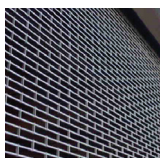

CUSTOM-DESIGNED SOLUTIONS

Contact our experienced Architectural Design Support Team for help in customizing our products to fit your specific application.

 www.architectdoorhelp.com